



Car Body Welding System

Catalogue Carrosserie • Karosserie-Schweißtechnik Katalog
Catálogo de Soldadura para Carrocería

2010D
www.gys.fr

Qualité certifiée

Certified quality
Geprüfte Qualität



(on-line download)

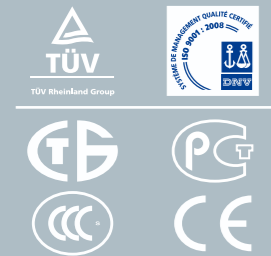

(on-line download)

Groupe industriel familial français depuis 1964 French family-owned industrial group since 1964 / Französischer Familienbetrieb seit 1964

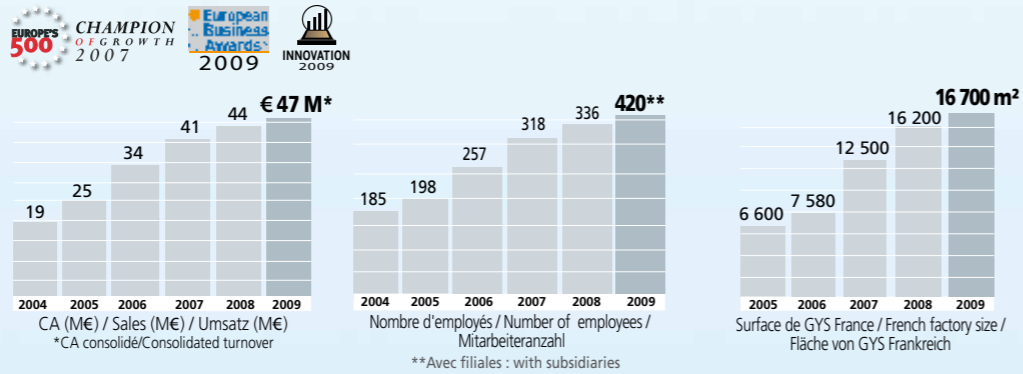

Trois gammes de produits en évolution permanente A growing portfolio of products / 3 Produktsegmente - Vielfalt durch dauerhafte Innovation

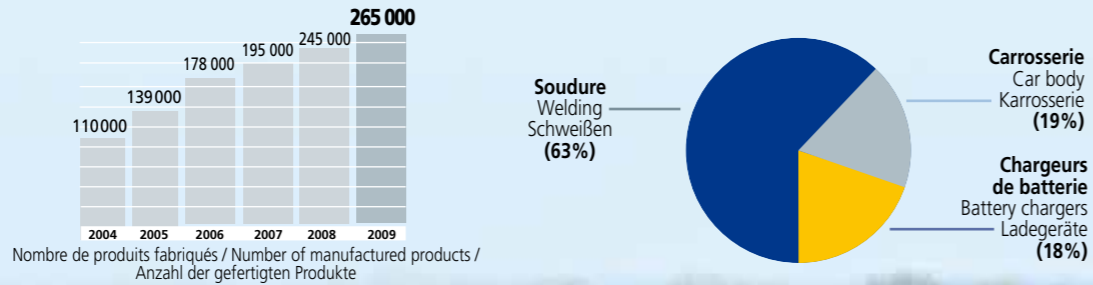

Nombre de produits fabriqués / Number of manufactured products / Anzahl der gefertigten Produkte



www.gys.fr

Quatre implantations : France, Allemagne, U.K, Chine. French headquarter with 3 subsidiaries abroad / 4 Standorte



Filiale commerciale / Commercial Subsidiary / Vertriebs & Service Niederlassung
Bureau d'achat & Fabrication de chargeurs grand public / Procurement & DIY Battery chargers production / Einkaufsbüro & DIY Ladegeräte-Fertigung

Des produits distribués dans 94 pays International coverage / Internationale Präsenz in 94 Märkten



Sommaire 386 références Table of contents / Inhaltsangabe

- Débosselage
- Dent Puller
- Ausbeulen
- Desabolladora
- Tira Mossas
- Urtdeuken
- Tira-bolli
- Правка кузова
- Τραβηκτικό
- 介子机

Dent Puller p.04-13

- Soudage par point
- Spot welding
- Punktschweißen
- soldadura por puntos
- soldadura por puntos
- Puntlassen
- Soldatura per punti
- Точечная сварка
- Ηλεκτρόπonta
- 点焊机

Spot Welding p.13-29

- MIG Carrosserie
- Car Body MIG
- MIG für Karosserieeinstandsetzung
- Soldadura Mig Para Carroceria
- MIG para Carroçarias
- Autoschade MIG
- Attrezzatura MIG per carrozzeria
- Полуавтоматы для Кузовного ремонта
- Μηχανή σφραγισμός φανοποιείας
- 车身维修专用的二氧化碳保护焊机

Car Body MIG p.30-33

- Découpeurs Plasma Carrosserie
- Car Body Plasma Cutter
- Plasmaschneidergeräte für Karosserieeinstandsetzung
- PLASMA
- Corte Plasma para Carroçarias
- Autoschade plasma snijder
- Attrezzatura per carrozzeria per tagliare con il plasma
- Плазменная Резка для Кузовного ремонта
- Κοπτικό μηχανήμα Plasma
- 切割机

Car Body Plasma cutter p.34

- Système de Chauffage par Induction
- Induction Heating System
- Induktionserhitzer
- Sistema De Induccion De Calor
- Máquina de Aquecimento por Indução
- Inductie heater systeem
- Sistema ad induzione di calore
- Аппарат Индукционного нагрева
- Επαγωγικό μηχανήμα θέρμανσης
- 电磁感应加热器

Induction Heating System p.35

- Outillage Carrosserie
- Car Body Tools
- Zubehör für Karosserieeinstandsetzung
- Herramientas De Carroceria
- Ferramentas para Carroçarias
- Gereedschap voor autoschadeherstel
- Attrezzatura per ambiente carrozzeria
- Инструменты для Кузовного ремонта
- Εργαλεία Φανοποιείας
- 车身工具

Car Body Tools p.38-41

- Consommables MIG
- Consumables for MIG
- MIG Verschleißteile
- Consumibles para Mig
- Consumíveis para MIG
- Verbruiksmaterialen voor MIG
- Ricambi per macchinari MIG
- Расходные материалы для полуавтоматов
- Αναλώσιμα για την MIG
- 二氧化碳保护焊机耗材

MIG Consumables p.42-43

Des produits homologués, Homologated products, Produktempfehlungen



Une production totalement intégrée Fully integrated production / Hochautomatisierte Serienproduktion



1250 tonnes de tôle par an / tons of metal-sheets per year
83M composants implantés en 2009 / components mounted in 2009
65 000 transformateurs en 2009 / transformers in 2009
428 types de connectiques fabriqués / connectors types manufactured
9000 pièces fabriquées par mois / pieces manufactured per month
20 chaînes de montage / lines for final product assembly
2 000 m² de stockage / storage area

29 chercheurs en R&D

researchers in R&D / hochqualifizierte Ingenieure in F&E



R&D Électronique & conception / Electronic & design
R&D Mécanique / Mechanics

Tôlerie / Steel Workshop • Électronique / Electronic • Transformateur / Transformer • Câblage / Cables Workshop • Atelier mécanique / Automated Precision

Workshop • Assemblage / Main Workshop • Magasin / Warehouse

GYSPOT 2400/35.02S/35.04S Débosseleur acier avec détection automatique de contact. Réglages simples et intuitifs.
ALUSPOT Appareil de redressement idéal pour les travaux rapides sur carrosseries aluminium.
GYSPOT ALU FV Alimentation 85 à 265V. Réglages simples et rapides (mode synergique). Pistolet à détection automatique.
GYSPOT COMBI 230 Appareil 2 en 1 permettant le débousselage de l'acier et de l'al. Le GYSPOT COMBI 230 est le partenaire idéal des ateliers cherchant de la rentabilité et de l'efficacité.
GYSPOT 2400/35.02S/35.04S Steel dent pulling machine with automatic contact ignition. Simple and intuitive settings.
ALUSPOT. Straightening machine ideal for quick works on aluminium car-body, using the "discharge capacity" technology.
GYSPOT ALU FV Mains supply from 85 to 265V Easy and fast settings (synergic mode). With automatic gun detection system.
GYSPOT COMBI 230 2 in 1 dent pulling machine for steel and aluminium. The GYSPOT COMBI 230 is the ideal product for workshops seeking efficiency and profitability.

GYSPOT 2400/35.02S/35.04S Ausbeuspotter für Stahl mit automatischer Kontaktzündung. Einfache und intuitive Bedienung.
ALUSPOT. Ausbeuspotter für Aluminium, Mikroprozessor gesteuert mit voreingestellter Temperaturkontrolle.
GYSPOT ALU FV. Stromversorgung von 85 bis 265 V. Einfache und schnelle Einstellung (Synergic Modus). Mit automatischem Pistolenerkennungssystem.
GYSPOT COMBI 230 Ausbeuspotter für Stahl und Alu, optimal zur Effizienz- und Rentabilitätssteigerung in der Werkstatt.
GYSPOT 2400/35.02S/35.04S Herramienta para desabollar el acero con detección automática del contacto. Reglajes simples e intuitivos.
ALUSPOT. Máquina de desabollar, indicada para realizar trabajos rápidos en carrocerías de aluminio, utilizando la tecnología de "Descarga de Condensadores".
ALUSPOT FV entregada de 85 a 365 v fácil y rápida de utilizar (modo sinérgico) con pistola automática.
GYSPOT COMBI 230 2 en 1 desabolladora para hierro y aluminio el gyspot system es el producto ideal para carrocerías facilitando la rentabilidad y la eficiencia.
GYSPOT 2400/35.02S/35.04S Polie de tracção em aço. Detecção automática por contacto. Regulações simples e intuitivas.
ALUSPOT. Máquina de pequenas dimensões ideal para trabalhos em carroçarias de alumínio, através da tecnologia de capacidade de descarga.
GYSPOT ALU FV Alimentação de 85 a 265V. Regulações fáceis e rápidas (modo sinérgico). Com sistema de detecção automática da pistola.
GYSPOT COMBI 230 Nova geração de máquinas 2 em 1 permitindo o pente com dentes do aço e do alumínio. A COMBI 230 é o sócio ideal das oficinas para quem procura o proveito e a eficiência.

GYSPOT 2400/35.02S/35.04S Uitdeukapparaat voor staal. Automatische contact detectie. Eenvoudige instellingen.
ALUSPOT. Uitdeukapparaat voor het snel uitdeuken van aluminium carrosserie door middel van ontladingstechniek.
GYSPOT ALU FV Hoofdvoeding van 85 tot 265 V Snel en eenvoudig in te stellen (synergie modus). Met automatische pistool herkenning.
GYSPOT COMBI 230 2 in 1 uitdeukapparaat voor staal en aluminium. De GYSPOT COMBI 230 is een ideaal apparaat voor autoschadeherstelbedrijven die op zoek zijn naar efficiëntie en winstverhoging.
GYSPOT 2400/35.02S/35.04S Battiliamiere acciaio con detezione automatica di contatto. Regolazioni semplici e intuitive.
ALUSPOT. Apparecchio di raddrizzatura ideale per i lavori veloci su carrozzerie in alluminio utilizzando la tecnologia della "scarica capacitiva"
GYSPOT ALU FV. Alimentazione da 85 a 265V. Comandi semplici e rapidi (modo sinérgico). Con sistema di rivelazione dotato di pistola automatica
GYSPOT COMBI 230 Tura-bolli 2 in 1 per acciaio e alluminio.
GYSPOT COMBI 230 è il prodotto ideale per le carrozzerie che cercano efficienza e profitto

GYSPOT 2400/35.02S/35.04S Аппарат для выправления стали с автоматическим детектором контакта. Простые и логичные настройки.
ALUSPOT. Аппарат для быстрого выправления кузовов из алюминия, оснащён технологией «ёмкостная разрядка»
GYSPOT ALU FV Питание от 85 до 265В. Простые и быстрые настройки (синергический режим). Пистолет с автоматическим детектированием.
GYSPOT COMBI 230 это новое поколение аппаратов 2 в 1, позволяющих править сталь и алюминий. COMBI 230 – это идеальная техника для ремонтных цехов, желающих совместить рентабельность и эффективность
GYSPOT 2400/35.02S/35.04S Τραβηκτικό μηχανήματα με αυτόματη αναγνώριση και απλές διαθεσιμικές ρυθμίσεις.
ALUSPOT. Το ιδανικό τραβηκτικό για γρήγορες εργασίες σε αμάξια αλουμινίου, που χρησιμοποιεί την τεχνολογία "discharge capacity"
GYSPOT ALU FV Δέχεται τροφοδοσία από 85 έως 265V Έυκολες και γρήγορες ρυθμίσεις (συνεργική λειτουργία). Με αυτόματο σύστημα ανίχνευσης πιστολιού.
GYSPOT COMBI 230 σε 1 τραβηκτικό μηχανήματα για χάλυβα και αλουμίνιο.
GYSPOT COMBI 230 είναι το ιδανικό προϊόν για φανοποιεία τα οποία αναζητούν αποδοτικότητα και κέρδος.
GYSPOT 2400/35.02S/35.04S 带自动接触感应的钢制介子机。简单明了的调节功能。
ALUSPOT. 应用"电容放电"技术的矫正机，最理想用于铝制车身的快速维修。
GYSPOT ALU FV : 电压范围从 85到265伏。简单明了的调节功能。(增效模式)。带自动接触感应焊接功能。
GYSPOT Combi 230 : 2合1 用于修复钢板和铝板的车身。高回报，高效能，GYSPOT Combi 230 是修理厂最理想的选择。

GYSPOT 2400 Acier/Steel /Stahl 230V



GYSPOT 35.02S Acier/Steel /Stahl 230V

GYSPOT 35.04S Acier/Steel /Stahl 400V



ALUSPOT Alu 230V



GYSPOT ALU FV Alu 110>240V

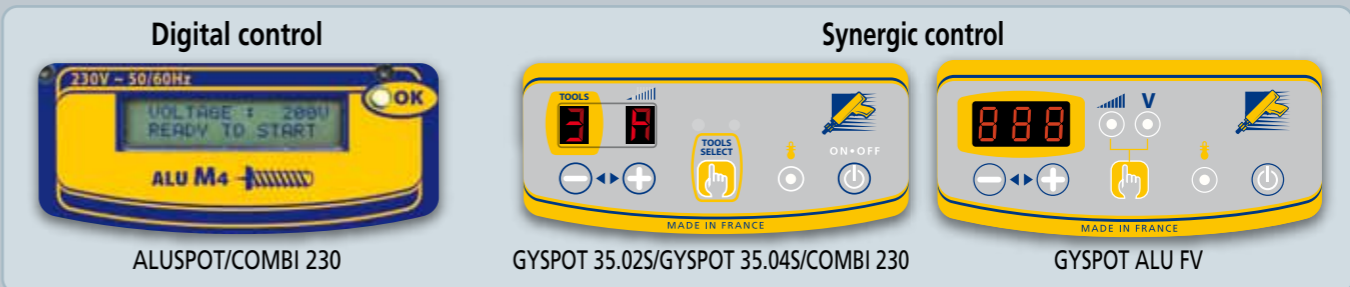

Support consumable box	Chariots • Trolleys • Fahrwagen	
 <p>Gyspot 35.02S Gyspot 35.04S Ref. 050624</p>	 <p>Trolley SPOT 800 Ref. 051331</p> <p>48 x 68 x 81</p>	 <p>Trolley SPOT 1600 Ref. 051348</p> <p>61 x 69 x 189</p>

	Icon	V	Hz	I _{RMS} 3%	I _{RMS} A	I ₂ MAX A	U ₂	cm	kg	OK	OK	SYNER-GIC	AUTO MATIC detection	SEPARATE Cable Gun
GYSPOT 2400	Ref.018006	230V	50 Hz	16	1700	2400	5,4	20x18x32	16	OK	—	—	•	—
GYSPOT 35.02S	Ref.018075	230V	50Hz	16	2700	3500	7,2	26x23,5x36	27	OK	OK	•	•	•
GYSPOT 35.04S	Ref.018082	400V	50Hz 2 ph	16	2700	3500	7,2	26x23,5x36	27	OK	OK	•	•	•
ALUSPOT	Ref.018846	230V	50/60Hz	3	—	7500	50 > 200	23x23,5x36	14	OK	OK	—	—	—
GYSPOT ALU FV	Ref.051546	110>240V	50/60Hz	5	—	7500	50 > 200	21x24x36	14	OK	OK	•	•	—
GYSPOT COMBI 230	Ref.020160	230V	50Hz	16	2700 (steel)	3500 (steel) 7500 (alu)	7,2 (steel) 50 > 200 (alu)	45x43x29	46,5	OK	OK	•	•	•

Étoiles • Stars • Ausbeulsterne • Estrellas



Clous • Nails • Nägel • Clavos



Rondelles • Washers • Ringe • Arandelas

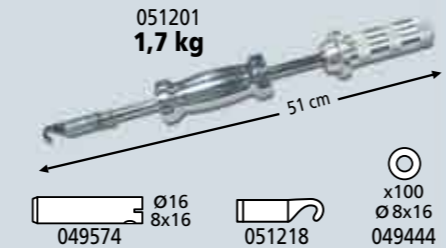

Griffes • Gripping multihook head • Ausbeulkit • Uñas

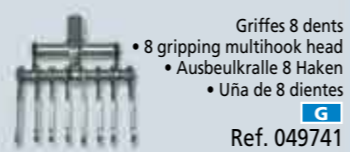
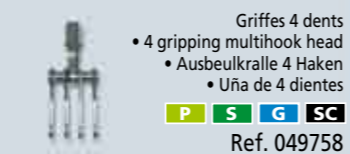
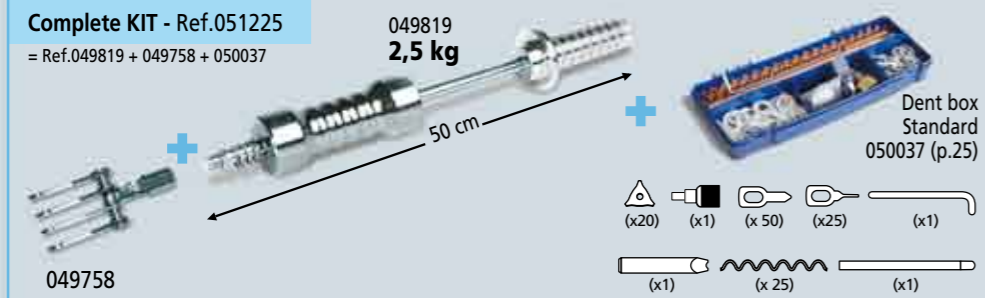

Levier de débosselage • Levelling lever • Zughebel • Palanca de alineación

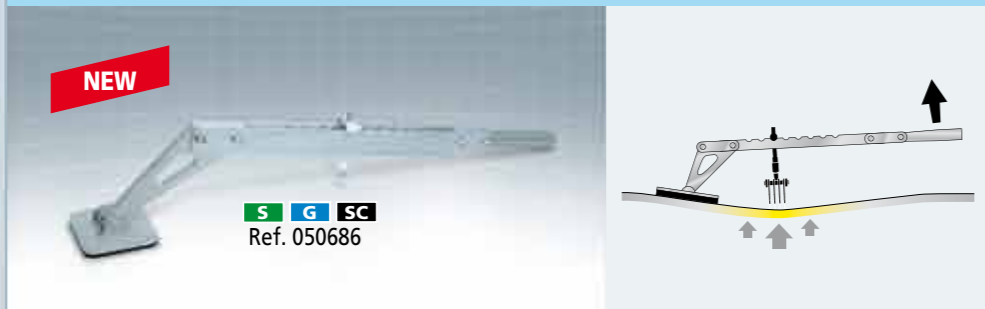

Barre de débosselage • Levelling bar • Zugbrücke • Barra de alineación



Barre de tirage • Lifting bar • Scherenzugbrücke • Barra de tiro

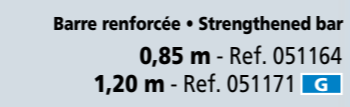
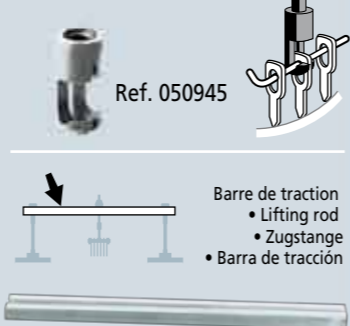

Manuspot/Manuliner

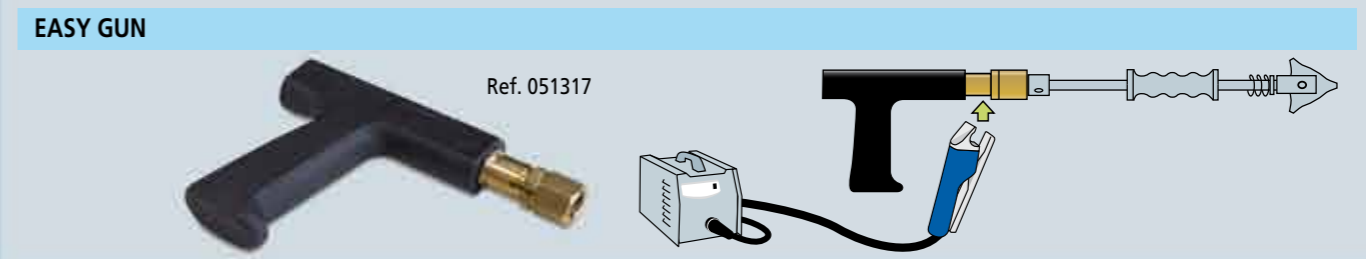
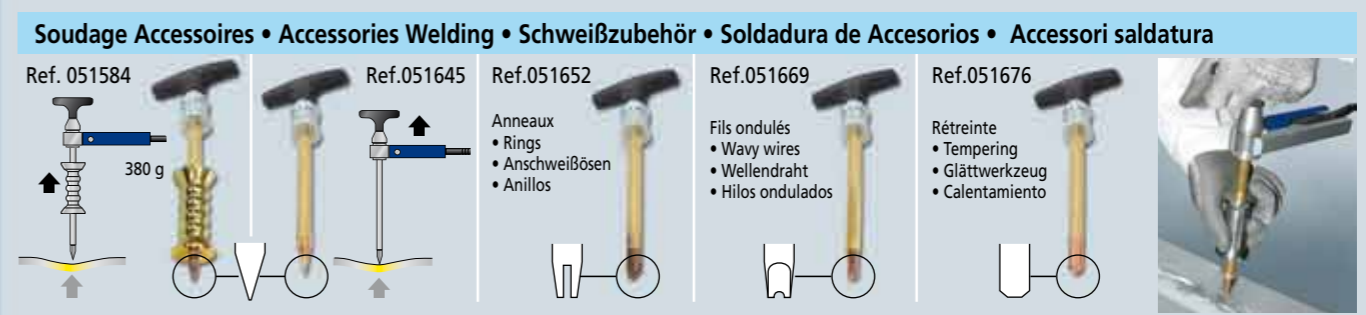
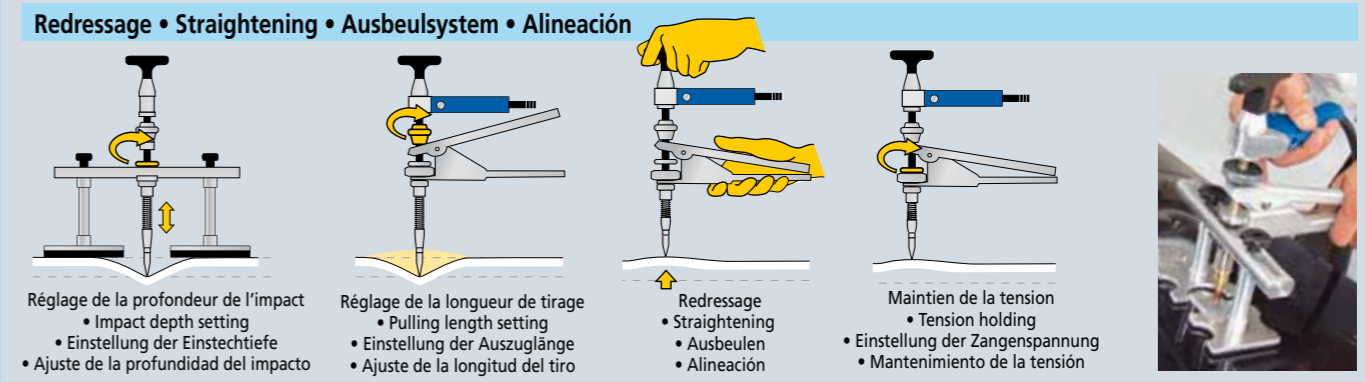

PROLINER, SPEEDLINER, GYSLINER
 Ensemble de débosselage rapide idéal pour les travaux sur bas de caisse, ailes ou pavillons. Avantages :

- réduire le temps d'immobilisation du véhicule
- améliorer la rentabilité de l'atelier
- réparer sans démontage

PROLINER, SPEEDLINER, GYSLINER
 Quick dent pulling set ideal for works on rocker panels, car fenders and roofs. Advantages:

- Reduce the vehicle immobilisation time
- Improve the workshop profitability
- Repair without dismantling

PROLINER, SPEEDLINER, GYSLINER Fahrbare Karosserie-Ausbeulstationen. Zeit- und platzsparend, für hohe Effektivität in der Karosserie-Werkstatt: • Reduzierung der Fahrzeug-Ausfallzeiten

- Zeitsparend und vielseitig
- Reparatur ohne Teileausbau

PROLINER, SPEEDLINER, GYSLINER Conjunto de desabollo rápido ideal para las obras en los largueros bajo puertas, aletas o techos. Ventajas : • reducir el tiempo de inmovilización del vehículo

- mejorar la rentabilidad del taller • reparar sin desmontar.

PROLINER, SPEEDLINER, GYSLINER Conjunto de pentes com dentes rápidos ajustado para trabalhos nos painéis das embaladeiras, nos guarda-lamas e nos telhados do veículo

Vantagens: • Reduz o tempo de imobilização do veículo • Melhora proveitosamente a oficina

- Reparar sem desmontar

PROLINER, SPEEDLINER, GYSLINER
 Quickpull set. Ideaal voor het uitdeuken van dorpels, wielkasten en daken. Voordelen:

- Aanzienlijke verkorting van de benodigde reparatietijd.
- Verhoging van het rendement in de werkplaats.
- Repareren zonder demontage van onderdelen.

PROLINER, SPEEDLINER, GYSLINER
 Kit rapido di riparazione delle ammaccature, ideale per lavorare su sottosocca, paraurti e tettini. Vantaggi:

- Riduzione del tempo di inutilizzo del veicolo.
- Miglioramento della redditività della carrozzeria.
- Riparazione senza smontare le parti.

PROLINER, SPEEDLINER, GYSLINER
 Набор инструментов для быстрой правки, идеальный для порожков, крыльев или крыш автомобилей. Преимущества : • снижает время простоя автомобиля

- улучшает рентабельность ремонтного цеха • ремонт без разборки автомобиля

PROLINER, SPEEDLINER, GYSLINER
 Γρήγορη επαναφορά ζυλιγμάτων, ιδανικό για εργασίες σε πόρτες, φτερά, καπό, & ουρανούς αυτοκινήτων. Πλεονεκτήματα: • Μειώνει το χρόνο ακινητοποίησης των οχημάτων • Βελτιώνει την αποδοτικότητα των φανοποιείων • Επισκευές χωρίς ξεμονταρίσματα.

PROLINER, SPEEDLINER, GYSLINER
 全套快速修复机系统、最合适与车身门槛踏板、车顶、侧围的钣金修复。优点: • 减少汽车修理时间 • 增加修理厂的赢利性 • 无需拆开车身进行修复

PROLINER P



SPEEDLINER S



GYSLINER G



					OPTION		
	Ref.	Ref.	Tools & accessories	Consumable box (p.13)	x6 x2	cm	kg
PROLINER 230	Ref.020375	—	P p.06-07	Ref 050037 + Ref 050075	Ref 051362	85x76x111	66
PROLINER 400	Ref.020382	—	P p.06-07	Ref 050037 + Ref 050075		85x76x111	66
SPEEDLINER	Ref.020412	—	S p.06-07	Ref 051515		61x69x189	75
SPEEDLINER 230	Ref.020399	—	S p.06-07	Ref 051515 + Ref 050075		61x69x189	102
SPEEDLINER 400	Ref.020405	—	S p.06-07	Ref 051515 + Ref 050075		61x69x189	102

					OPTION		
	Ref.	Ref.	Tools & accessories	Consumable box (p.13)	x6 x2	cm	kg
GYSLINER	Ref.050754	—	G p.06-07	—	Ref 051362	102x57x180	85
GYSLINER W 3502S	Ref.050761	GYSPOT 35.02S p.04	G p.06-07	Ref 050075		102x57x180	112
GYSLINER W 3504S	Ref.050778	GYSPOT 35.04S p.04	G p.06-07	Ref 050075		102x57x180	112
WORKSTATION	Ref.050747	—	—	—		102x57x180	60

Glue Puller (Acier/Alu • Steel/Alu)

Glue Puller Ref. 050990
= Ref. 050921 + Ref. 050969 + Ref. 050952 + Ref. 050976 + Ref. 050983

included

- (x10) Ref. 050976
- Ref. 050983

NEW OPTION
Ref. 050051

Consommables Alu • Alu consommables • Alu-Verbrauchsmaterial • Consumibles para aluminio

ALU BOX STANDARD - Ref 050020

ALU BOX LIGHT - Ref 051522

		in box	
Goujons • Stud • Espárragos			
	Alu magnésium	050273 (x200)	x200
		050129 (x1000)	x200
	Alu silicium	050280 (x200)	x200
		050136 (x1000)	x200
Mandrin de traction pour M4 Tension Madrel for M4 Schubhülse für M4 Mandril de tracción para M4		050327 (x1)	
Anneaux • Rings • Anschweißöse • Anillos			
		050297 (x5)	x5
		050792 (x3)	x1
		050945 (x1)	
		050938 (x1)	
Mandrin pistolet • Madrel for gun			
		049000 (x2)	

Masse pistolet alu • Earth clamp for Alu gun

NEW

Ref. 051683

Accessoires • Accessories

Marteaux • Hammer • Martillo
• 铝制锤子

ALU

Ref. 020986

Consommables acier • Steel consumables • Stahl-Verbrauchsmaterial • Consumibles para acero

DENT BOX STANDARD
Ref 050037

SPOTTER BOX
Ref 050075

DENT BOX CONSUMABLES
Ref 051515

		in box	
Étoiles • Stars • Ausbeulsterne • Estrellas			
	049451 (x20)	x20	
	049482 (x1)	x1	
Rondelles • Washers • Ringe • Arandelas			
	Ø16 8x16 049574 (x1)	x1	
	Ø8x16 049444 (x100)	x50	
	051218 (x1)		
Écrous • Lock nuts • Mutter • Tuercas • Dadi			
	Ø16 049567 (x1)		
	M8 050303 (x100)		
Rivets/Goujons • Rivets/Stud • Bolzen • Roblones/Espárragos			
	Ø16 3x4,5 049604 (x1)	x1	
	Ø3x3,25 049345 (x100)	x100	
	Ø3x4,50 049352 (x100)	x100	
	Ø2-M4 049277 (x1)		
	Ø5-M5-M6 049598 (x1)	x1	
	M4x16 049383 (x100)	x50	
	Ø5x12 049413 (x100)	x50	
	Ø5x18 049420 (x100)	x50	

		in box	
Anneaux • Rings • Anschweißösen • Anillos			
	050655 (x1)	x1	
	050648 (x100)	x50	
	050631 (x50)	x25	
	050792 (x3)	x1	
Fils ondulés • Wavy wires • Wellendraht • Hilos ondulados			
	049789 (x1)	x1	
	049727 (x50)	x25	
		x25	
Positionneur magnétique • Magnetic positionner • Magnetischer Positionierer • Posicionador magnetico			
	049772 (x1)		
Monopoint • Spot Welding • Monopunkten • Monopunto			
	049291 (x1)		
	Caps Type F 049970 (x6)		
Point à la molette • Electrode wheel • Rollnahtschweißen • Electrodo ruleta			
	Ø16 050310 (x1)		

		in box	
Clous • Nails • Nägel • Clavos			
	Ø2-M4 049277 (x1)		
	Ø5-M5-M6 049598 (x1)		
	Ø2 041561 (x100)		
Rétreinte • Tempering • Glättwerkzeug • Calentamiento • Restricción			
Electrodes carbone chauffe-tôle Carbon electrodes warming Karbonatelektroden zur Blechvorwärmung Electrodos de carbon calefaccion		049468 (x5)	x1
	Ø16 049567 (x1)	x1	
Masse magnétique • Magnetic earth • Magnetische Masse • Masa magnetica			
	049666 (x1)		
	050013 (x1)	x1	
Autres • Others • Sonstige • Diversos			
	27 049673 (x1)	x1	

Masse pistolet acier • Earth clamp for Steel gun

NEW

Ref. 051997

Manuspot / Manuliner (p19)

Direct impact electrodes (X 5)
Ref. 050839

Box of 3 electrodes for accessories
Ref. 050822

ÉVOLUTION TECHNOLOGIQUE

TECHNICAL IMPROVEMENTS • TECHNISCHE ENTWICKLUNG
• MEJORAS TECNICAS

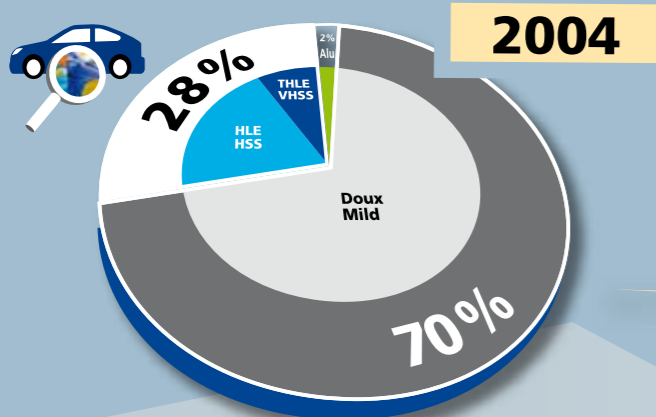

2004

GYS solutions	
Traditional machines	
180 daN max	
6 500 A max	
X clamps	
	Ø 4 mm max

- Facteurs d'évolution**
- Challenge CO² = faible poids
 - Crash test = ★★★★★
 - Anti corrosion = nouveaux revêtements
 - Esthétique et visibilité plus sophistiquées.
- Evolution factors**
- CO² Challenge = low weight
 - Crash test = ★★★★★
 - Anti-corrosion = new coatings
 - Improved aesthetics and demand for better occupant visibility.

- Mehr Vorteile durch**
- CO² Challenge = geringes Gewicht
 - Crash-Test = ★★★★★
 - Anti-Korrosion = neue Beschichtung
 - Modernes Technik-Design.
- Factores de evolución**
- Challenge CO² = peso débil
 - Ensayo de choque = ★★★★★
 - Anti-corrosión = nuevos revestimientos
 - Diseño y visibilidad mas sofisticadas

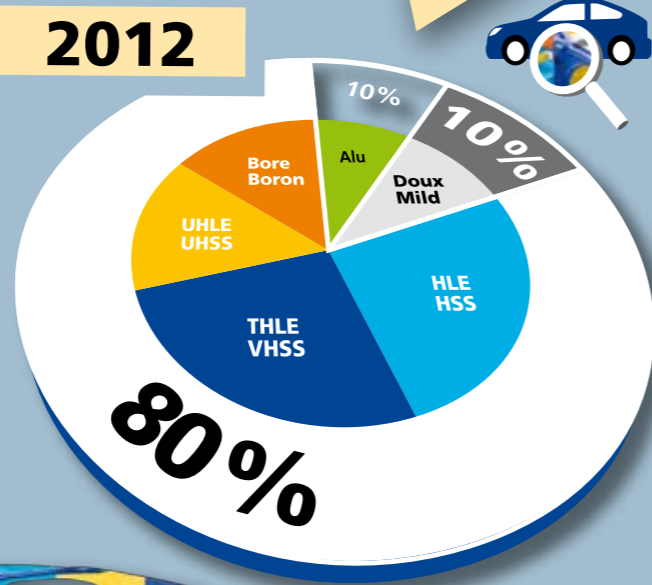

2012

GYS solutions	
INVERTER Technology	
550 daN max	
14 500 A max	
X & C clamps	
	Liquid cooled system
	Ø 10 mm

- Doux Mild
- HLE HSS
- THLE VHSS
- UHLE UHSS
- Bore Boron
- Alu

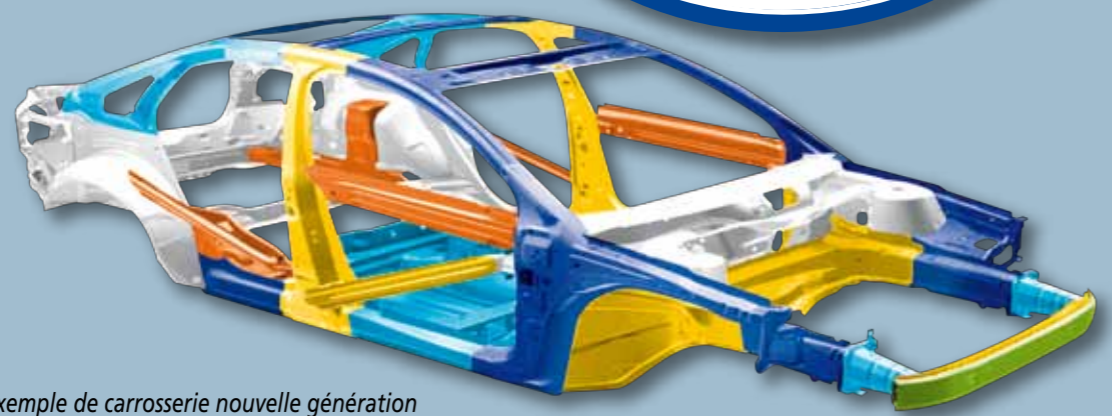

Exemple de carrosserie nouvelle génération
• An example of new generation car body • Beispiel einer Karosserie der neuen Generation
• Ejemplo de la nueva generacion de carrocerias

BODYPROTECT TECHNOLOGY®

2004-40-CE UNIQUE ELECTRO-MAGNETIC FIELD PROTECTION by GYS

© BODYPROTECT is a proprietary GYS technology that reduces to the minimum, electromagnetic fields created by the machine.
Compliant : Directive 2004-40-CE / Certified by : Laboratory **EMITECH**

LA SOLUTION GLOBALE

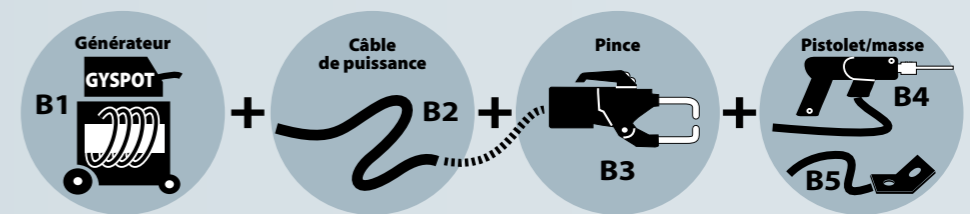

Other Technologies



B2	10 > 25 cm (Norm : 3 cm max)	
B3	25 > 35 cm (Norm : 30 cm max)	
B4	35 cm (Norm : 20 cm max)	
B5	35 cm (Norm : 20 cm max)	

GYS BODYPROTECT TECHNOLOGY



B2	0 cm (Norm : 3 cm max)	
B3	4 cm (Norm : 30 cm max)	
B4	0 cm (Norm : 20 cm max)	
B5	0 cm (Norm : 20 cm max)	

- | | | | |
|--|---|--|--|
| <p>BODYPROTECT, GYS :</p> <ol style="list-style-type: none"> 1- Apporte une solution originale et unique à la problématique du champ électromagnétique. 2- Résout complètement l'exposition d'un carrossier aux risques des champs magnétiques. 3- Permet à chaque utilisateur de pratiquer son métier sans contrainte. 4- Garantit une maniabilité optimale de la pince. | <p>BODYPROTECT, GYS :</p> <ol style="list-style-type: none"> 1- Brings an original and unique solution to the electromagnetic fields problematic. 2- Resolves totally the problem of exposure to the radiations for the car body repair man. 3- Enables every user to do his own job without restraint. 4- Grants an optimum manoeuvrability of the clamp. | <p>BODYPROTECT, GYS :</p> <ol style="list-style-type: none"> 1- Ist eine einzigartige, innovative Lösung für die Elektromagnetfeld-Problematik. 2- Bietet optimalen Anwenderschutz ohne das Risiko elektromagnetischer Strahlung. 3- Beibehaltung der ergonomischen Voraussetzungen. 4- Sorgt für optimale Arbeitsbedingungen ohne Einschränkung der Zangendrehung. | <p>BODYPROTECT, GYS :</p> <ol style="list-style-type: none"> 1- Lleva una solución original y única a la problemática del campo electro-magnético. 2- Resuelve completamente la exposición de un carroceros a los riesgos de los campos magnéticos. 3- Permite a cada utilizador de practicar su profesión sin molestia. 4- Garantiza una manejabilidad óptima de la pinza. |
|--|---|--|--|

GYSPOT 32D-X & 32D-C. Soudeuses par point à courant alternatif. Ces machines possèdent un mode synergique évitant à l'utilisateur le réglage du temps et l'intensité de soudage.

GYSPOT 32D-X & 32D-C. Alternative current Spot welders. These machines feature a synergic mode avoiding the user the setting of the welding time and intensity.

GYSPOT 32D-X & 32D-C. Luftgekühlte Punktschweißmaschinen zum Schweißen von Karosseriestahlblechen. Mit synergischer Regelung von Schweißzeit und Schweißstrom.

GYSPOT 32D-X & 32D-C. Punteadoras con corriente alterna. Dotadas con un modo sinérgico que ahorra el reglaje del tiempo y de la intensidad de soldadura.

GYSPOT 32D-X & 32D-C. Máquinas de Soldar de corriente alternativa. Estas máquinas caracterizam uma modalidade sinérgica evitando que o utilizador ajuste o tempo e a intensidade da solda.

GYSPOT 32D-X & 32D-C. Alternatieve hedendaags spotters. Deze machines beschikken over een synergie-regeling en voorgeprogrammeerde instellingen.

GYSPOT 32D-X & 32D-C. Saldatrici spot a corrente alternata. Queste macchine rendono possibile una sinergia con l'utente che evita a quest'ultimo di dover impostare la durata della saldatura e l'intensità.

GYSPOT 32D-X & 32D-C. Аппараты контактной сварки на переменном токе. Эти аппараты имеют синергичный режим, что позволяет избежать настройки продолжительности сварки и сварочного тока.

GYSPOT 32D-X & 32D-C. Ηλεκτρόπιοντες Εναλλασόμενου Ρεύματος. Αυτές οι μηχανές διαθέτουν έναν συνεργικό τρόπο, αποφεύγοντας ο χρήστης τον καθορισμό του χρόνου και της έντασης συγκόλλησης.

GYSPOT 32D. 交流点焊机。采用增效模式，避免用户自己调节焊接时间和电流。

GYSPOT 32D-X

7 500 A • 500 daN
Air Cooled
Cable : L = 2,5 m - Ø = 200 mm²

Air Cooled
Cables : L = 2,5 m - Ø = 150 mm²

INCLUDED :

Monopoint/Spot welding Ref. 049291 (x1)
SPOTTER BOX Ref. 050075 (p.13)
Ref. 049802

RX1
l = 120 mm
Ref 051034
8 bar / 500 daN

RX2
l = 220 mm
Ref 051041
8 bar / 300 daN

RX3
l = 220 mm
Ref 051058
8 bar / 300 daN

Consommables*Consumables p.28-29

6 kg including RX1
DOUBLE PRESSURE
Ø 8 mm



3 ARMS INCLUDED



3 ARMS INCLUDED

GYSPOT 32D-C

7 500 A • 300 daN
Air Cooled
Cable : L = 2,5 m - Ø = 200 mm²

Air Cooled
Cables : L = 2,5 m - Ø = 150 mm²

INCLUDED :

Monopoint/Spot welding Ref. 049291 (x1)
SPOTTER BOX Ref. 050075 (p.13)
Ref. 049802

RC1
57 mm
Ref 051065
8 bar / 300 daN

RC2
106 mm
Ref 051072
8 bar / 300 daN

RC3
120 mm
220 mm
450 mm
Ref 051089
8 bar / 300 daN

Consommables*Consumables p.28-29

4 kg including RC1
Ø 8 mm

Easy large opening
360° Clamp rotation



Ref.	50 /60Hz	CAMP	RMS A	MAX A	mm	U ₀ V	Cables			100% Cu	cm	kg	
							AIR COOLED	l	Ø mm ²				
GYSPOT 32D-X Ref.019881	2x 400	32 (D)	7500	10500	3+3	1,2+3	11	•	2,2m	200	•	55x75 x190	100
								•	2,5m	150			
								•	8m	3x6 H07RNF			

X Arms / Consumables ... page 28-29

Ref.	50 /60Hz	CAMP	RMS A	MAX A	mm	U ₀ V	Cables			100% Cu	cm	kg	
							AIR COOLED	l	Ø mm ²				
GYSPOT 32D-C Ref.019898	2x 400	32 (D)	7500	10500	3+3	1,2+3	11	•	2,2m	200	•	55x75 x190	100
								•	2,5m	150			
								•	8m	3x6 H07RNF			

C Arms / Consumables ... page 28-29

Automatic Mode Choose thickness

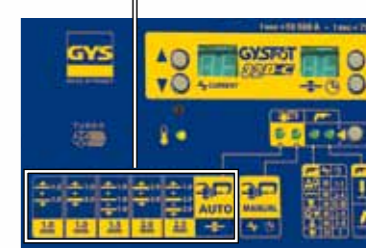

GYSPOT 100R-X & 100R-C. Soudeuses par point de type INVERTER. Idéal pour le soudage de nouveaux aciers Haute résistances. Equipé d'origine de la mesure dynamique du courant, du réglage automatique de l'effort de serrage et de la traçabilité des points de soudure.

GYSPOT 100R-X & 100R-C. INVERTER spot welders. Ideal to weld the new HTS steels. Originally equipped with: dynamic current measurement, automatic setting of the tightening strength and welding spots tracking.

GYSPOT 100R-X & 100R-C. Inverter-Punktschweißgeräte. Besonders geeignet für hochfeste neue Stähle. Ausgestattet mit dynamischer Strom- und automatischer Anpressdrucküberwachung sowie Schweißdatenerfassung über SD-Karte.

GYSPOT 100R-X & 100R-C. Punteadora con corriente continua. Ideal para la soldadura de los nuevos aceros de Alta Resistencia. Equipada de origen con medida dinámica de la corriente, regulación automática de la fuerza de apriete y trazabilidad de los puntos de soldadura.

GYSPOT 100R-X & 100R-C. Máquinas de Soldar por puntos de corrente directa. Ideal para soldar os novos aços HTS Equipado de origem com: medida dinâmica de corrente, ajuste automático da força de aperto e seguimento dos pontos da solda.

GYSPOT 100R-X & 100R-C. Gangbare continu spotters. Ideaal voor het lassen van de nieuwe hoog gelegerde staalsoorten. Standaard uitgevoerd met een dynamische vermogensmeting en automatische instelling van de aandrukkracht en puntlascontrole.

GYSPOT 100R-X & 100R-C. Saldatrici spot a corrente continua. Ideali per saldare i nuovi acciai HTS. Munite di: misurazione dinamica della corrente, regolazione automatica della stretta e tracciabilità dei punti di saldatura.

GYSPOT 100R-X & 100R-C. Аппарат контактной сварки на постоянном токе. Идеален для сварки новых высокопрочных сталей. Изначально оснащён системой измерения динамики тока, автоматической регулировкой силы сжатия и системой отслеживания сварных точек.

GYSPOT 100R-X & 100R-C. Ηλεκτρόπνοτες Συνεχούς Ρεύματος. Ιδανικό για να συγκολληθούν τους νέους HTS χάλυβες. Εξοπλισμένος με: δυναμική τρέχουσα μέτρηση, αυτόματος καθορισμός της σκληρότητας και ανιχνευσιμότητα των σημείων συγκόλλησης.

GYSPOT 100R-X & 100R-C. 是采用逆变技术的直流点焊机。它是专为焊接最新的高强度钢而设计的理想点焊机。本机器采用动态的电流测量、夹紧力自动调节、以及焊点的可追溯性。

For Mild, HSS, UHSS

GYSPOT 100R-X INVERTER

10 000 A • 500 daN
Air Cooled
Cable : L = 2,5 m - Ø = 200 mm²

Air Cooled
Cables : L = 2,5 m - Ø = 150 mm²

INCLUDED :

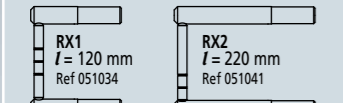
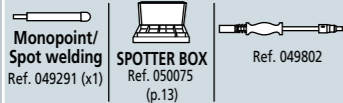

8 bar / 500 daN 8 bar / 300 daN

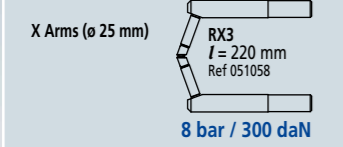

8 bar / 300 daN
Consommables*Consumables p.28-29



	50/60Hz	I _{RMS} A	3% A	mm	U ₀ V	Câbles			100% Cu	cm	kg
						AIR COOLED	l	Ø mm ²			
GYSPOT 100R-X Ref.019911	3x 400	32 (D)	10000	3+3	1,5+3	16		• 2,5m	200	• 70x99 x208	103
								• 2,5m	150		
								—	8m		

X Arms / Consumables ... page 28-29



For Mild, HSS, UHSS

GYSPOT 100R-C INVERTER

10 000 A • 300 daN
Air Cooled
Cable : L = 2,5 m - Ø = 200 mm²

Air Cooled
Cables : L = 2,5 m - Ø = 150 mm²

INCLUDED :

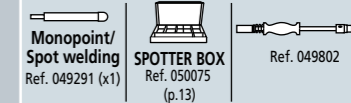

8 bar / 300 daN 8 bar / 300 daN

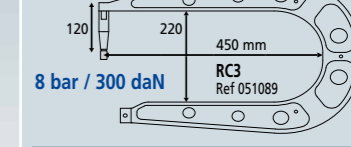

8 bar / 300 daN
Consommables*Consumables p.28-29

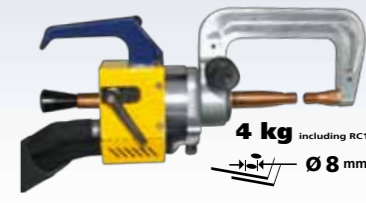

Digital Screen 100RX & 100RC
(More details p.26)

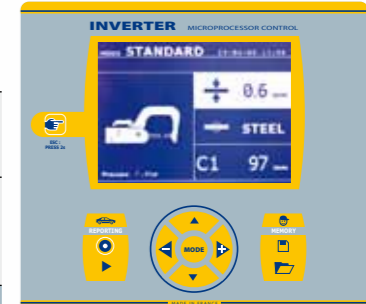

	50/60Hz	I _{RMS} A	3% A	mm	U ₀ V	Câbles			100% Cu	cm	kg
						AIR COOLED	l	Ø mm ²			
GYSPOT 100R-C Ref.019928	3x 400	32 (D)	10000	3+3	1,5+3	16		• 2,5m	200	• 70x99 x208	103
								• 2,5m	150		
								—	8m		

C Arms / Consumables ... pages 28-29

FR GYSPOT BP LX & BP LC : Soudeuses par point de type INVERTER incluant la **technologie Body Protect**, avec régulation automatique de l'effort de serrage et fort courant de soudage. Nombreuses fonctions : traçabilité des points de soudure, mémorisation des paramètres personnels, enregistrement sur carte SD...

DE GYSPOT BP LX & BP LC : Inverter-Punktschweißanlage mit **Body-Protect-System** inklusive automatischer Regelung von Anpreßdruck und Schweißstrom. Neue Funktionen: Schweißdatenerfassung, Speicherung von Anwenderprogrammen, Aufzeichnung über SD-Karte.

IT GYSPOT BP LX & BP LC : INVERTER puntlasapparaat, voorzien van **BODY PROTECT technologie**, met automatische instelling van de aandrukkraft. Vele functies: controle van de puntlas, las parameters opslaan in het geheugen, data overdracht via SD kaart.

GR GYSPOT BP LX & BP LC : Απάρat κoντακτiκoύ σωαρκι INΒΕΡΤΕΡOΠOύ τiπoς τεχνολoγiα **Body Protect**, σ ατoματiκoύ ρεγυλiωτικoύ σiμiς σжатiα και βoλiσμoυ σωαρчoνiкoυ τoκoυ. Μnoгoчiслeνнeς фuнкцiи: oтσeλiвaнiе σoвepшeннoς σωαρчoнoς тoчeк, σoχρaσiнe iнdиvиdυαλнoς пaρaмeтpoв, зaπiσh δaннoς нa κaρτa SD...

UK GYSPOT BP LX & BP LC : INVERTER spot welder, including **Body Protect technology**, with automatic adjustment of the tightening force. Many functions : traceability of the welding points, personal parameters storage, recording on SD card.

ES GYSPOT BP LX & BP LC : Punteadora de tipo INVERTER, con **tecnología Body Protect** y regulación automática de la fuerza de apriete. Numerosas funciones : trazabilidad de los puntos de soldadura, memorización de los parámetros personales, salvaguardia sobre tarjeta SD.

IT GYSPOT BP LX & BP LC : Saldatore spot INVERTER, con **tecnologia "Body Protector"** e regolazione automatica della forza di serraggio e della corrente di saldatura. Numerose funzioni: tracciabilità dei punti di saldatura, memorizzazione dei parametri usati dal tecnico, salvataggio su scheda SD.

GR GYSPOT BP LX & BP LC : INVERTER ηλεκτροπoντα, σμπεριλαμβανομeνoυ τoυ **Body Protect technology**, με τiн αυτoματi η ρυθμiση τiς δυναμiς σκληρoτητα. Πολλeς λειτoυργιeς: aνιχeυσιμoτητα των συγκoλλησεων, πpoσωπiкi aπoθiкeυσι παρaμeтpoв, κaтaρaφi σε κaρτa SD.

CH GYSPOT BP LX / BP LC : 采用车身保护技术的逆变型点焊机, 带夹紧力度自动调节装置. 多种功能: 焊接点可追溯性, 个人设置的存储, 在SD卡上的记录保存...

For Mild, HSS, UHSS & Boron steel

GYSPOT BP LX INVERTER

13 000 A • 550 daN
Liquid Cooled
Cable : L = 2,5m - Ø = 200 mm²

Air Cooled
Cables : L = 2,5 m - Ø = 150 mm²

INCLUDED :

Monopoint/ Spot welding Ref. 049291 (x1) | SPOTTER BOX Ref. 050075 (p.13) | Ref. 049802

X1 Ref 050501
8 bar / 550 daN

Consumables • Consumables p.28-29

Régulation automatique de la force de serrage et du courant de soudage
Automated regulation of the tightening force and welding current
Automatisch geregelter Zangenanpressdruck

BODYPROTECT TECHNOLOGY
2004-40-CE UNIQUE ELECTRO-MAGNETIC FIELD PROTECTION by GYS

0 cm (Norm : 3 cm) | **5 cm max** (Norm : 30 cm max)

©BODYPROTECT is a proprietary GYS technology that reduces to the minimum electromagnetic fields yield by the machine.
Compliant : Directive 2004-40-CE
Certified by : Laboratory **EMITECH**

Ref. 050068 | **Housse de protection**
Protection cover
Schutzhaube
Ref. 050853

UPGRADE V1 > V2

KIT GYSPOT BP LX Ref. 051393
KIT GYSPOT BP LC Ref. 051751

CARD SD Management
Ref. 051621



	50/60Hz	A	A	mm	U _o	Câbles (l / Ømm ²)	100% Cu	cm	kg
GYSPOT BP LX Ref.019652	3x400	32 (D)	13000	3+3+3	1,5+3	2,5m/200 LIQUID	AIR	65x80 x205	160

X Arms / Consumables ... page 28-29

For Mild, HSS, UHSS & Boron steel

GYSPOT BP LC INVERTER

13 000 A • 550 daN
Liquid Cooled
Cable : L = 2,5m - Ø = 200 mm²

Air Cooled
Cables : L = 2,5 m - Ø = 150 mm²

INCLUDED :

Monopoint/ Spot welding Ref. 049291 (x1) | SPOTTER BOX Ref. 050075 (p.13) | Ref. 049802

C1 Ref 019140
8 bar / 550 daN

Consumables • Consumables p.28-29

Régulation automatique de la force de serrage et du courant de soudage
Automated regulation of the tightening force and welding current
Automatisch geregelter Zangenanpressdruck

BODYPROTECT TECHNOLOGY
2004-40-CE UNIQUE ELECTRO-MAGNETIC FIELD PROTECTION by GYS

0 cm (Norm : 3 cm) | **4 cm max** (Norm : 30 cm max)

©BODYPROTECT is a proprietary GYS technology that reduces to the minimum electromagnetic fields yield by the machine.
Compliant : Directive 2004-40-CE
Certified by : Laboratory **EMITECH**



	50/60Hz	A	A	mm	U _o	Câbles (l / Ømm ²)	100% Cu	cm	kg
GYSPOT BP LC Ref.019669	3x400	32 (D)	13000	3+3+3	1,5+3	2,5m/200 LIQUID	AIR	65x80 x205	160

C Arms / Consumables ... pages 28-29

Option GYRO 360°
For BPLC Ref 051737

NEW

GYSPOT BP LCX : Version double pinces (C et X) de la série BPL, souplesse d'utilisation et ergonomie sont les points forts de cette machine. Caractéristiques techniques identiques aux versions BPLX et BPLC.

GYSPOT BP LCX : Double clamp version (C and X) of the BPL range. Flexible use and ergonomoy are the main assets of this machine. Same technical characteristics as for the BPLX and BPLC versions.

GYSPOT BP LCX : Doppelzangenversion (C u. X-Zange) der BP-L Baureihe. Flexibler Einsatz und Ergonomie zeichnen dieses mit den gleichen technischen Eigenschaften wie BPLX u. BPLC ausgestattete Gerät aus.

GYSPOT BP LCX : Versión con doble pinza (C y X) en nuestra gama BPL. Flexibilidad de uso y ergonomía son las principales ventajas de esta máquina. Las características técnicas son idénticas a las versiones BP.LX y BP.LC.

GYSPOT BP LCX : Versão com pinça dupla (C e X) na nossa gama BPL. Flexibilidade de uso e ergonomia são as principais vantagens desta máquina. As características técnicas são idênticas às das versões BP.LX e BP.LC.

GYSPOT BP LCX : Dubbele lastang (C en X) voor de BPL serie. Veelzijdig en ergonomisch zijn belangrijke voordelen van deze machine. Zelfde technische eigenschappen als de BPLX en BPLC versie.

GYSPOT BP LCX : La gamma BPL comprende anche la versione con doppia pinza (C e X). I principali vantaggi di questa macchina sono la flessibilità d'uso e l'ergonomia. Le caratteristiche tecniche sono le stesse delle versioni BPLX e BPLC.

GYSPOT BP LCX : ηλεκτρόπνοτα, συμπεριλαμβανομένου του Body Protect technology, με την αυτόματη ρύθμιση της δύναμης σκλήρυνσης. Πολλές λεπτομέρειες: ανιχνευσιμότητα των συγκολλησεων, προσιπτική αποθήκευση παραμέτρων, καταγραφή σε κάρτα SD.

GYSPOT BP LCX : Βερсия серии BPL с двумя типами клещей (C и X), гибкость в использовании и эргономика - это сильные стороны этого аппарата. Технические характеристики идентичны версиям BPLX и BPLC.

GYSPOT BP LCX : 带双焊钳(C和X字型)的BP.L系列点焊机,使用的灵活性和人机工程学的运用是该机器的最大特色。技术参数和BP.LX和BP.LC两款一样。

Dernière née des GYSPOT, l'**EVOLUTION** est une réelle avancée technologique dans le domaine du soudage par résistance. Sa pince en C intègre un transformateur MF capable de délivrer un fort courant de soudage sur un disjoncteur de 16A.

Last-born among the GYSPOT range, the **EVOLUTION** is a real technological advance in the area of resistance welding. Its C-clamp has an integrated MF transformer able to deliver high welding current on a 16A circuit breaker.

Die neueste Entwicklung der GYSPOT Baureihe, die **EVOLUTION PTI**, stellt einen großen technischen Fortschritt in der Punktschweißtechnologie dar. Die mit einem integrierten MF-Transformator ausgestattete C-Zange liefert bereits bei 16 Ampere Netzabsicherung hohe Schweißströme.

Recién nacida en nuestra gama GYSPOT, la **EVOLUCION** es un real avance tecnológico en el campo de la soldadura por resistencia. Su pinza en C tiene un transformador MF integrado capaz de suministrar una corriente de soldadura muy alta con un disyuntor de 16A.

Recém nascida na nossa gama GYSPOT, a **EVOLUCION** é um real avanço tecnológico no campo da soldadura por resistência. A sua pinça em C tem um transformador MF integrado capaz de fornecer uma corrente de soldadura muito alta sobre um disjuntor de 16A

De nieuweling in de GYSPOT serie, de **EVOLUTION** heeft groot technische voordeel in het weerstand lassen. De C-tang heeft een geïntegreerde MF transformator die in staat is om een hoog vermogen te leveren op een 16A zekering.

Ultima nata della gamma GYSPOT, la **EVOLUTION** è un effettivo passo in avanti nel campo della saldatura per resistenza. La sua pinza in C ha un trasformatore MF integrato in grado di inviare su un disgiuntore da 16A, una corrente di saldatura molto elevata.

Τελευταία κατασκευασμένη μεταξύ της σειράς GYSPOT, η **EVOLUTION** είναι μια πραγματική τεχνολογική εξέλιξη στον τομέα της συγκόλλησης. Ο C σφικτήρας έχει έναν ενσωματωμένο μετασχηματιστή MF ικανό να μεταφέρει υψηλό ρεύμα συγκόλλησης με μια παροχή 16Α.

Последняя модель серии GYSPOT: **EVOLUTION** - это настоящая продвижение технологий в области сварки сопротивлением. С-клещи с трансформатором MF, который способен выдать мощный сварочный ток на предохранитель в 16А.

最新一代的GYSPOT点焊机,它的演变是电阻焊接领域一个真正的技术改进。它的C型焊钳带一个中频变压器,可以承受在16安培开关上的高电流焊接。

For Mild, HSS, UHSS & Boron steel

GYSPOT BP LCX INVERTER

13 000 A • 550 daN
Liquid Cooled
Cable : L = 2,5m - Ø = 200 mm²

Air Cooled
Cables : L = 2,5 m - Ø = 150 mm²

INCLUDED :

Monopoint/Spot welding Ref. 049291 (x1) SPOTTER BOX Ref. 050075 (p.13) Ref. 049802

C1 Ref 019140
8 bar / 550 daN

X1 Ref 050501
8 bar / 550 daN

Consommables•Consumables p.28-29

Régulation automatique de la force de serrage et du courant de soudage
Automated regulation of the tightening force and welding current
Automatisch geregelter Zangenanpressdruck

BODYPROTECT TECHNOLOGY
2004-40-CE UNIQUE ELECTRO-MAGNETIC FIELD PROTECTION by GYS

4 cm max (Norm : 30 cm max)
5 cm max (Norm : 30 cm max)

0 cm (Norm : 3 cm)
0 cm (Norm : 3 cm)

©BODYPROTECT is a proprietary GYS technology that reduces to the minimum electromagnetic fields yield by the machine.
Compliant : Directive 2004-40-CE
Certified by : Laboratory EMITECH

Ref. 050068
Housse de protection
Protection cover
Schutzhaube
Ref. 050853

UPGRADE V1 > V2

KIT GYSPOT BP LCX Ref. 051744
KIT GYSPOT EVOLUTION PTI Ref. 051386

CARD SD Management Ref. 051621



	50/60Hz	A	A	mm	U _o	Câbles (L / Ømm ²)	100%	cm	kg		
GYSPOT INVERTER BP LCX Ref.019676	3x	400	32 (D)	13000	3+3+3	1,5+3	16	2,5m / 200 LIQUID	2,5m / 150 AIR	65x80 x205	180

X Arms / C Arms / Consumables pages 28-29

For Mild, HSS, UHSS & Boron steel

GYSPOT EVOLUTION INVERTER

14 500 A • 550 daN
Liquid Cooled + Air Cooled
Cable : L = 4m or 6m

Transformer inside

FUSE 16 > 25 A

INCLUDED :
C1 Ref 019140 97
8 bar / 550 daN
89 mm

Consommables•Consumables p.28-29

Régulation automatique de la force de serrage et du courant de soudage
Automated regulation of the tightening force and welding current
Automatisch geregelter Zangenanpressdruck

2,5 cm (Norm : 30 cm)
9 cm (Norm : 30 cm)
0 cm (Norm : 3 cm)
7 cm (Norm : 30 cm)

Compliant : Directive 2004-40-CE
Certified by : Laboratory EMITECH

Option GUN

Complete kit Ref.051010

Option GYRO 360°

For BPLC/BPLCX Ref 051737
For EVOLUTION Ref 051720

NEW



	50/60Hz	A	A	mm	U _o	Câbles (L / Ømm ²)	100%	cm	kg		
GYSPOT EVOLUTION PTI (6M) Ref.020320	3x	400	25 (D)	14 500	3+3+3	1,5+3	16	4m / 200 AIR	6m / 230	60x80 x230	100

C Arms / Consumables page 28-29

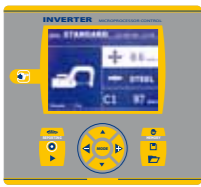

DIGITAL SCREEN

(EVOLUTION, B.P.LCX, B.P.LC, B.P.LCX, 100RC, 100RX)

CHOOSE PROGRAMS

MANUAL STANDARD MULTI AUTO

TOOLS SELECT

CONTROL SPOT

OK ERROR

SPOT DONE WARNING: "Insufficient pressure", or "Insert SD card", or "Do control caps"..."

SAVE PARAMETERS

SD CARD MEMORY

SAVE JOB

SD CARD MEMORY

CATALOG

N°	X/C	I(A)	F(dav)	Observation
1				
2				
3				
4				
5				
6				
7				
8				
9				
10				
11				
12				
13				
14				
15				
16				
17				
18				
19				
20				
21				
22				
23				
24				
25				

EXPORT DATA

SD CARD

YOUR LOGO

Company name : GYS Phone number : 02 43 68 35 21
 Address : 134, Bd des Loges Fax number : 02 43 68 35 22
 Zip code : 53940 Email : contact@gys.fr
 City : SAINT-BERTHEVIN Website : http://www.gys.fr

Operator : TCM Vehicle : ALFA ROMEO
 Repair order : CD2345 Registration : 113AMZ53
 Report date : 21/05/2008 First Registration : 10/10/2004
 Remarks : COMMENT Operation : REAR FENDER

GYSPT INVERTER BP.LC (1111111111)

Point N°	Date / Hour	Mode	Tool	Settings		Measurements		State	
				Time (ms)	Intensity (SA)	Force (dIN)	Force (dIN)		
1	21/05/2008 11:45:45	Normal	C clamp n°1	370	7,6	240	7,6	235	Point OK
2	21/05/2008 11:45:51	Normal	C clamp n°1	370	7,6	240	7,6	240	Point OK
3	21/05/2008 11:49:30	Manual	X clamp n°1	370	7,6	550	7,6	485	Low Pressure
4	21/05/2008 12:16:14	Manual	C clamp n°5	310	7,5	195	7,4	195	Point OK
5	21/05/2008 12:16:24	Manual	C clamp n°4	310	7,5	195	7,4	195	Point OK
6	21/05/2008 12:16:46	Manual	C clamp n°4	310	7,5	195	7,4	190	Point OK
7	21/05/2008 11:48:27	Normal	C clamp n°5	370	7,6	240	7,5	235	Point OK

IDENTIFIEZ VOTRE ACIER • IDENTIFY YOUR STEEL IDENTIFIZIEREN SIE DIE STAHLHÄRTE • IDENTIFIQUE SU ACERO

GYSTEEL VISION Ref. 051096

Resistance (MPa)

1500
1000
500

DOUX MILD HLE HSS UHLE UHSS BORE BORON

10 20 30 40 50

GYSTEEL VISION Result

REGISTER ONLINE TEST CERTIFICATE

Material Test Certificate

Vehicle information:

Vehicle make	Model	Year (model)	License no.
VEHICLE	MODEL	YEAR	LICENSE

Search manufacturers recommended repair method.

Analysed test value: 32
Test side: Left

TESTED MATERIAL INFORMATION:

EHS steel:
DP (DualPhase) and TRIP-Steels obtain their increased strength by heat-treatment during manufacture. In TRIP-Steel also retained austenite, which is converted to martensite (I) during deformation.

Welding and straightening:
Both steels are very sensitive to heat, even at low temperatures and for short periods, so restrictions on heating and welding apply. Straightening is limited because of the high elastic limit and hardness. The harder materials require special tool, ex. titanium bits for drilling, cutting etc.

Analysed test value: 37

TESTED MATERIAL INFORMATION:

LHS steel

FOR : 32 DX • 100 RX • BP LX • BP LCX — (ø 25 mm) + Caps ø 13 mm

FOR : EVOLUTION PTI • BP LCX • BP LC — Caps ø 13 mm

550 daN
6,5 kg including X1

- DOUBLE PRESSURE
- LIQUID COOLED / REFRROIDISSEMENT LIQUIDE
- Ø 10 mm

Remote Control (BP)

Digital screen control
Change Mode & Parameters

Clamp control

550 daN
6,5 kg including C1

- DOUBLE PRESSURE
- LIQUID COOLED / REFRROIDISSEMENT LIQUIDE
- Ø 10 mm

550 daN
Transformer inside

- DOUBLE PRESSURE
- AIR COOLED + LIQUID COOLED / DOUBLE REFRROIDISSEMENT AIR + LIQUIDE
- Ø 10 mm

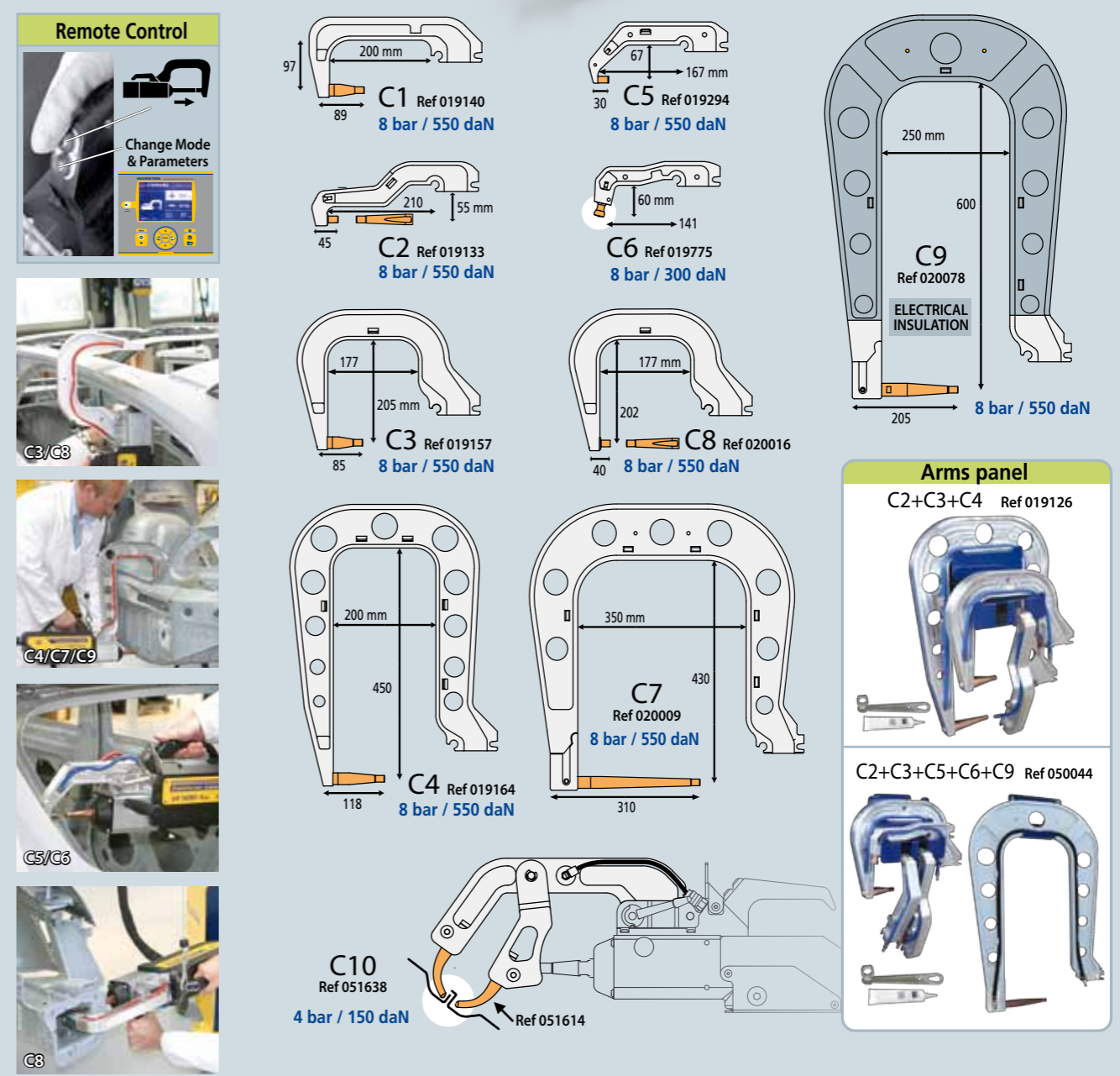
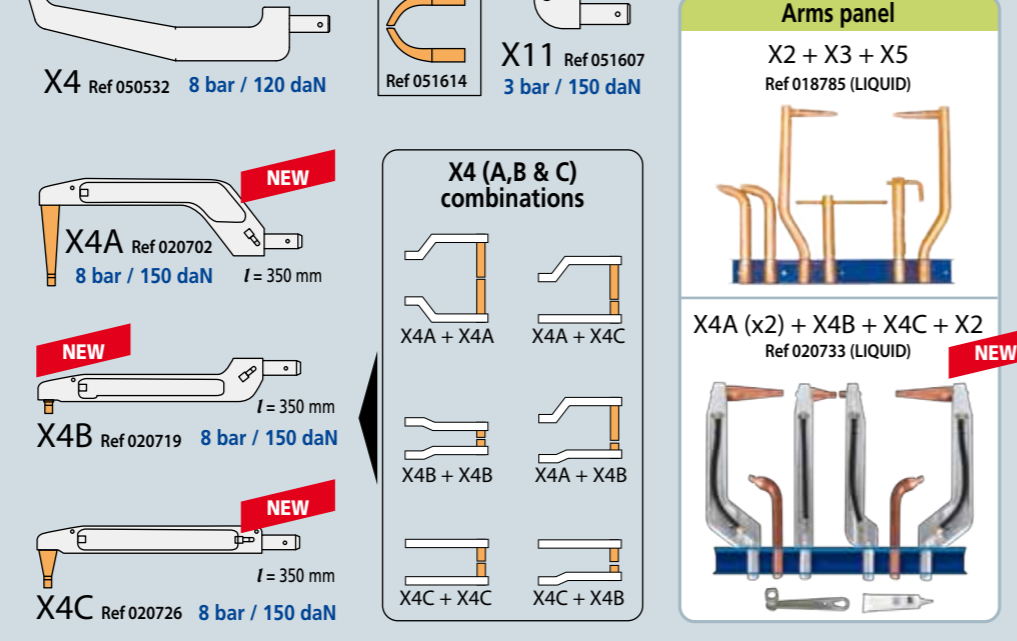
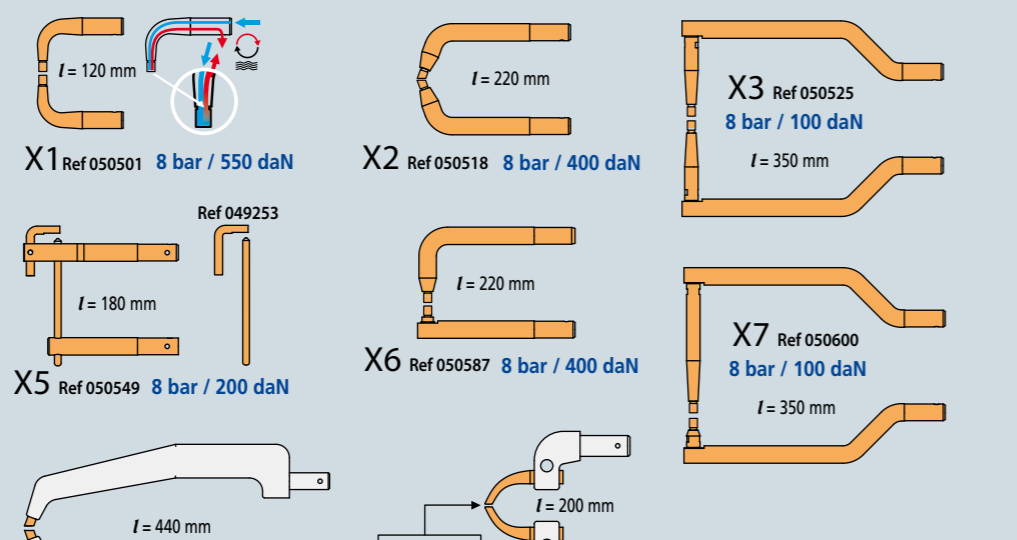
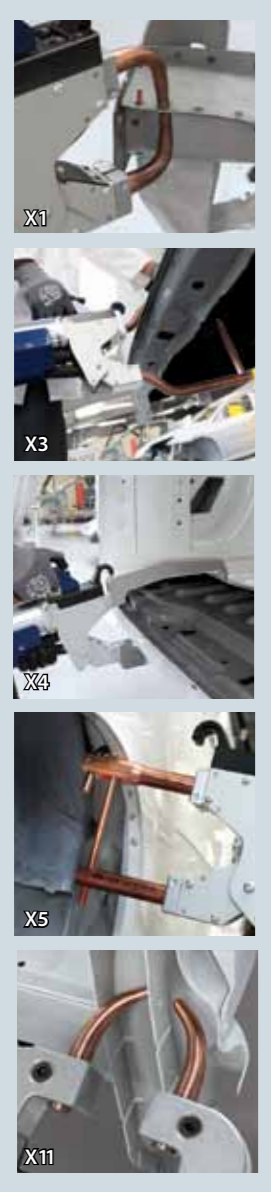

Point Control Tests
Ref. 050433

Tôle / Sheet / Schweißprobenbleche
HLE / HTS 1,0 mm (x150) Ref 050181
THLE / VHTS 2,5 mm (x150) Ref 050167

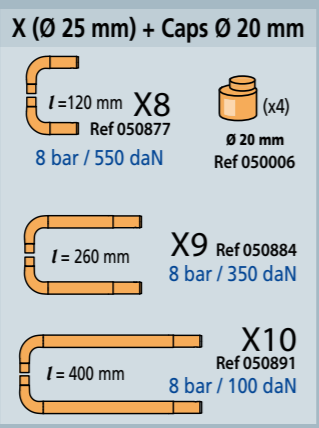

Consommables • Consumables

Caps remove Ref 050846

Graisse contact lubricate contact Ref 050440

Boîte consommables Spotter • Welding Spotter consumable • Zubehör für Punktschweißanlagen Ref 050068

GYRO 360°

NEW

For BP.LC/BP.LCX Ref 051737

For EVOLUTION Ref 051720

POSTES MIG/MAG SYNERGIC
Contrôlé par microprocesseur, les postes Synergic définissent par défaut la vitesse de fil idéale.

MONOGYS 185-2S : poste monophasé 230V pour petits travaux de tôlerie. Il peut recevoir la torche motorisée Spool Gun

TRIMIG 205.4S, DUOGYS & T3GYS : Idéals pour le soudage des aciers, Alu, Inox et le soudo-brasage des tôles Haute-Résistances. Ils peuvent recevoir la torche motorisée Spool Gun pour le soudage des aluminiums. Sur le T3GYS, la sélection des torches est automatique.

TRIMIG 385-4S : ce poste de forte puissance est idéal pour les ateliers de maintenance.

TRIMIG 390-4S : ce poste évolutif de forte puissance est idéal pour les réparations PL.

MIG/MAG SYNERGIC MACHINES

Microprocessor controlled Synergic Machines automatically set the optimum wire speed.

MONOGYS 185-2S : single phase 230V product for small sheet metal work. It can also be used with a spool gun.

TRIMIG 205.4S, DUOGYS & T3GYS : Ideal for welding steel, aluminium, stainless steel and for brazing high-resistant steel. It can be used with a spool gun to weld aluminium. On the T3GYS, the torch selection is automatic.

TRIMIG 385-4S : This high performance machine is ideal for maintenance jobs.

TRIMIG 390-4S : This evolutive high performance machine is ideal for HGV repair.

MIG/MAG SYNERGISCHE GERÄTE
Die Mikroprozessorgesteuerten synergischen Geräte regulieren automatisch die optimale Drahtvorschubgeschwindigkeit.

MONOGYS 185-2S : Einphasiges 230V Gerät für leichte Blecharbeiten. Auch für Spool Gun Brenner geeignet.

TRIMIG 205.4S, DUOGYS & T3GYS : Ideal für Stahl, Edelstahl, Alu-Dünn- und hochfeste Karosseriebleche. Mit Spool Gun Brenner zum Alu-Schweißen. Die Anwahl des Brenners an der T3GYS erfolgt automatisch.

TRIMIG 385-4S : Dieses leistungsstarke Gerät ist ideal für Wartungsarbeiten.

TRIMIG 390-4S : Dieses leistungsstarke Gerät mit externem Drahtvorschub ist ideal für LKW-Reparaturen.

MAQUINAS DE SOLDAR SINERGICAS

Control para micorprocesador sinergico. Maquinas automaticas que regulan la velocidad ideal de hilo

Monogys 185-2S : Monofásica 230V producto para pequeñas reparaciones de metal. Se puede utilizar tambien con la spool Gun

TRIMIG 384-4S DUOGYS & T3gys : Ideal para soldar aceros normales, aluminio, cobre silicio y alta resistencia.

Se puede utilizar con la pistola Spool Gun para soldar aluminio. En la T3GYS la selección de antorcha es automática.

TRIMIG 385-4S : Esta maquina de fuerte pulsacion es ideal para trabajos de mantenimiento.

TRIMIG 390-4S : está máquina evolutiva, de fuerte potencia, es ideal para las reparaciones de vehículos pesados.

MÁQUINAS MIG/MAG SINÉRGICAS Control sinérgico por microprocesador. Ajuste automático da velocidade do fio ideal.

MONOGYS 185-2S : Monofásica 230 V, para pequenos trabalhos de chapa. Pode receber pistola tipo "Spool Gun"

TRIMIG 205.4S, DUOGYS & T3GYS : Ideal para soldadura de aços, alumínio, aço inoxidável e brasagem para aços alta resistência elástica. Pode ser utilizada pistola tipo "spool gun" para a soldadura de alumínio. O modelo T3GYS, a seleção da tocha é automática.

TRIMIG 385-4S : Máquina de alta performance, ideal para trabalhos de manutenção.

TRIMIG 390-4S : Este equipamento evolutivo de alto desempenho é ideal para reparações em veículos pesados (HGV)

MIG/MAG SYNERGIE MACHINES Microprocessor gestuurde Synergie machine die automatisch de optimale draadnelheid kiezen.

MONOGYS 185-2S 1-fase 230 V machine voor licht plaatwerk. Kan ook gebruikt worden met een spool gun.

TRIMIG 205.4S, DUOGYS & T3GYS Ideaal voor het lassen van staal, aluminium, RV5 en hard solderen van hoogsterkte staal. Kan ook gebruikt worden met een spool gun om dun aluminium te lassen. Kiest automatisch de juiste toorts.

TRIMIG 385-4S Deze zware machine is ideaal voor onderhoudswerk.

TRIMIG 390-4S Deze machine levert prima lasprestaties en is uitermate geschikt voor werkzaamheden aan vrachtwagens.

MACHINE SINERGICHE MIG/MAG Macchine sinergiche controllate da microprocessore. Regolano automaticamente la velocità ottimale del filo.

MONOGYS 185-2S : macchina fase singola, 230V. Per piccoli lavori su lamiera di metallo. E' possibile connettere la pistola a bobina integrata.

TRIMIG205.4S, DUOGYS, T3GYS : Ideali per saldare acciaio, alluminio, acciaio inossidabile e per la brasatura degli acciai ad elevata resistenza. Per saldare l'alluminio, queste macchine possono utilizzare la pistola a bobina integrata. Nella T3GYS, la scelta della torcia è automatica.

TRIMIG 385-4S : E' ideale per i lavori di manutenzione.

TRIMIG 390-4S : Saldatrice che garantisce risultati di elevata qualità, ideale per le riparazioni sui veicoli pesanti.

ΑΠΑΡΑΤΗ ΜΙG/MAG SYNERGIC Благодаря микропроцессорному управлению, аппараты Synergic определяют по умолчанию идеальную скорость подачи.

MONOGYS 185-2S : однофазный аппарат 230В для мелких работ по листовому металлу. К нему можно подключить приводную горелку Spool Gun

TRIMIG 205.4S, DUOGYS & T3GYS : Идеальны для сварки стали, алюминия, нержавеющей и для сварки-пайки высокопрочных сталей. К ним можно подключить приводную горелку Spool Gun для сварки алюминия. На T3GYS выбор горелки происходит автоматически.

TRIMIG 385-4S : это мощный аппарат идеален для ремонтных цехов.

TRIMIG 390-4S : эволюционный аппарат большой мощности, идеален для ремонта грузовых автомобилей.

Συνεργικά μηχανήματα Mig/Mag

Συνεργικά μηχανήματα ελεγχόμενα από μικροεπεξεργαστή τα οποία αυτόματα διαμορφώνουν την καλύτερα αποδοτική ταχύτητα σύρματος.

MONOGYS 185-2S : μονοφασικό 230V προϊόν για εργασία σε μικρό φύλλο μετάλλου. Μπορεί επίσης να χρησιμοποιηθεί με πιστόλι συγκόλλησης Spool.

TRIMIG 205.4S, DUOGYS & T3GYS : Ιδανικό για συγκόλληση χάλυβα, αλουμίνιο, ανοξείδωτο και για brazing συγκόλληση υψηλής αντοχής χάλυβα. Μπορεί να χρησιμοποιηθεί με ένα πιστόλι συγκόλλησης Spool για την συγκόλληση αλουμινίου. Στο T3GYS, η επιλογή ταμπιδας γίνεται αυτόματα.

TRIMIG 385-4S : Αυτή η υψηλής απόδοσης μηχανή είναι ιδανική για εργασίες συντήρησης.

TRIMIG 390-4S : Αυτό το υψηλής απόδοσης εξελιγμένο μηχανήματα είναι ιδανικό για επισκευή σε βαριά φορτηγά.

增效二氧化碳保护焊机

微处理器控制，增效模式：焊机自动调节最理想的焊丝速度。

MONOGYS 185-2S : 230伏 单相二氧化碳保护焊机专用于车身的小维修。它也可以使用送丝枪。

TRIMIG 205.4S, DUOGYS & T3GYS : 具备钢材、不锈钢、铝、以及高强度钢的焊接钎焊功能。它们可以使用专用铝焊丝的送丝枪。T3GYS的焊枪选择是全自动。

TRIMIG 385-4S : 在车间做维护这台大功率二氧化碳保护焊机是最理想的工具。

TRIMIG 390-4S : 该新改良的高能电焊机，最适用于大货车的维修。

MONOGYS 185-2S
Ref. 033245

TRIMIG 205-4S
Ref. 019904

DUOGYS AUTO
Ref. 033016

Ref. 017252

T3GYS
Ref. 033108

Ref. 033023

TRIMIG 385-4S
Ref. 033450 (no accessories)

WF 4R
Ref. 033580 (option)

5 m (ø 50 mm²)
Ref. 033603

10 m (ø 50 mm²)
Ref. 033610

DUOGYS 390-4S
Ref. 033535 (no accessories)

AUTO ADAPTATIVE WIRE SPEED



Torche motorisée Spool Gun - Motorisiertes Spool Gun Brenner

Ref 041486

Ref 045699

Ref 041493

	50/60 HZ	A	Amax	40°C EN 60974-1	60%	Ø mm	Reg	cm	kg	KVA	Spool gun			
MONOGYS 185-2S Ref 033245	230	13	25 > 180	140A	70A	0,6 mm 0,8 mm	0,8 mm	0,6>1,0	4	47 x 77 x 79	50	4,5	option	
TRIMIG 205-4S Ref 019904	400	10	15 > 205	150A	110A	0,6 mm 0,8 mm	3 m	0,8 mm	0,6>1,0	7	47 x 77 x 79	55	5	option
DUOGYS AUTO Ref 017252	230/400	10	15 > 205	150A	110A	0,6/0,8 mm 0,8/1,0 mm	3 m	2 x 0,8 mm	0,6>1,0	7	60 x 90 x 90	72	5	included
T3GYS Ref 033023	400	10	15 > 205	150A	110A	0,6/0,8 mm 0,8/1,0 mm	3 m	2 x 0,8 mm	0,6>1,0	7	60 x 90 x 90	72	5	included
TRIMIG 385.4S Ref 033450	400	25	40 > 385	370A	280A	0,8 mm 1,0 mm	—	—	0,6>1,6	14	50 x 90 x 88	100	17	—
TRIMIG 390.4S Ref 033535	400	25	40 > 385	370A	280A	0,8 mm 1,0 mm	—	—	0,6>1,6	14	50 x 90 x 88	100	17	—

DUOGYS AUTO

Ref. 033016

Ref. 017252



2 x 4 m³ max
2 x 20 l max

GAZ GAZ

100% Ready

1 CONNECTION

DUOGYS	T3GYS

2 DETECTION

DUOGYS	T3GYS
Manual 	Auto

3 POWER

DUOGYS	T3GYS

4 HOLDER

DUOGYS	T3GYS
NO	 + Ref 041493

5 CAR MANUFACTURER

DUOGYS	T3GYS

6 TENSION - VOLTAGE

DUOGYS	T3GYS
TRI	TRI
230V	—
400V	400V

T3GYS

Ref. 033108

Ref. 033023



2 x 4 m³ max
2 x 20 l max

GAZ GAZ

NEW

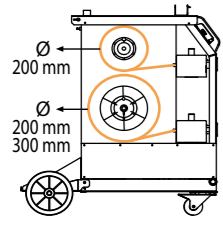

	50/60 HZ	A	Amax	60%	40°C EN 60974-1	EQUIPE D'ORIGINE-ORIGINAL EQUIPMENT ORIGINALAUSSTATTUNG EQUIPAMIENTO DE FABRICA	Ø mm	Reg	cm	kg	KVA	Spool gun		
DUOGYS AUTO Ref 017252	230/400 3~	10	15 >205	150A	110A	0,6/0,8 mm 0,8/1,0 mm	3 m	2 x 0,8 mm	0,6>1,0	7	60 x 90 x 90	72	5	included
T3GYS Ref 033023	400 3~	10	15 >205	150A	110A	0,6/0,8 mm 0,8/1,0 mm	3 m	2 x 0,8 mm	0,6>1,0	7	60 x 90 x 90	72	5	included

Règlage automatique de la vitesse - Auto adaptative wire speed
- Automatische Einstellung der Drahtgeschwindigkeit



Accessories box



Torche motorisée Spool Gun
- Spool Gun Brenner m. Antrieb

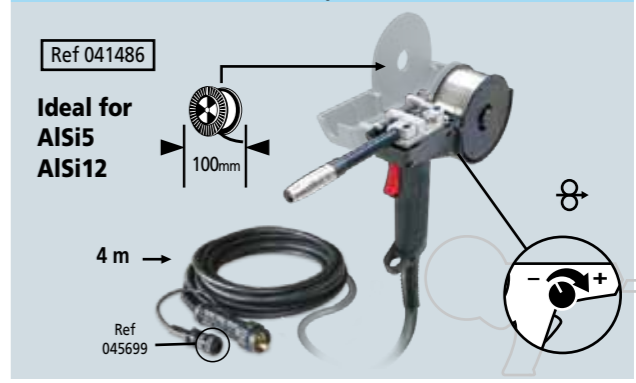

DECOUPEURS PLASMA à air comprimé monophasés pour acier, inox (jusqu'à 6 ou 10 mm), alu (jusqu'à 4 ou 8 mm) Amorage par arc pilote "self start". Le modèle Cutter 21K, avec compresseur incorporé, se rend indispensable en l'absence d'air comprimé. Cutter 31 FV "flexible voltage" s'adapte automatiquement suivant la tension (de 85V à 265V).

PLASMA CUTTERS with compressed air, single-phase For Stainless steel (up to 6 or 10 mm), Aluminium (up to 4 or 8 mm). Starting with Arc Pilot 'self start' The Cutter 21 K model is mostly needed when no compressed air supply is available. Cutter 31 FV "flexible voltage" automatically adapts to the electrical supply (from 85V to 265V).

Einphasige PLASMASCHNEIDGERÄTE mit Druckluftbetrieb Für Edelstahl bis 6 oder 10 mm + Alu bis 4 oder 8 mm. Zündung mit "self start" Arc Pilot. Typ 21K, mit eingebautem Kompressor ist unabhängig von einer externen Druckluftversorgung. Cutter 31 FV "Flexible Spannung" Automatische Erkennung und Adaption der Netzspannung zwischen 85V-265V.

CORTADORES PLASMA con aire comprimido, monofásicos para Acero, Inox (hasta 10mm), Aluminio (hasta 8 mm). Cebado por arco piloto "self start". El modelo Cutter 21K, con compresor incorporado, se convierte en un aparato indispensable si no se dispone de aire comprimido. Cutter 31 FV "flexible voltage" se ajusta automáticamente según la tensión (de 85V a 265V).

Máquinas de corte de plasma com ar comprimido, monofásica para inox (até 10 mm), alumínio (até 8 mm) Arranque com Arc Pilot programado/automático. É necessário utilizar o modelo CUTTER 21K, se não houver ar comprimido disponível. Cutter 31 FV "flexible voltage" Adapta-se automaticamente à tensão de alimentação (85V a 265V).

Plasma snijder op 220V voor staal, RVS (tot 10mm nauwkeurig) en aluminium tot 8mm. Uitgerust met 'self start' zodra de toorts wordt bediend. Het model Cutter 21K is uitgerust met een ingebouwde compressor, zodat er geen apart lucht netwerk aanwezig hoeft te zijn. Cutter 31 FV "flexibel voltage" past zich automatisch aan volgens de spanning (van 85V naar 265V).

TAGLIATORI PLASMA ad aria compressa monofase per Acciaio Inox (fino a 10mm) alluminio (fino a 8mm) Innesco tramite arco pilota "self start". Il modello Cutter 21K, con compressore incorporato, si rende indispensabile in assenza di aria compressa. Cutter 31 FV "Voltaggio flessibile". Si adatta automaticamente alla linea elettrica (da 85V a 265V).

ΚΟΠΤΙΚΟ PLASMA με αέρα από τον αεροσυμπιεστή, μονοφασικό. Για ανοξείδωτο χάλυβα (πάνω από 10mm), Αλουμίνιο (πάνω από 8 χιλ.) Έναρξη με Arc Pilot "self start" **ΚΟΠΤΙΚΟ PLASMA 21 K** διαθέτει ενσωματωμένο αεροσυμπιεστή. Cutter 31 FV "μεταβλητής τάσης" Η συσκευή αναγνωρίζει αυτόματα την τιμή της τάσης τροφοδοσίας (από 85V έως 265V).

ПЛАЗМЕННЫЕ РЕЗЧИКИ однофазные на сжатом воздухе. Для нержавеющей сталей (до 10 мм) и алюминия (до 8 мм). Самовоспламеняющийся розжиг дуги. Модель Cutter 21K с интегрированным компрессором является незаменимой при отсутствии сжатого воздуха. Cutter 31 FV "flexible voltage" а автоматически настраивается в зависимости от напряжения (от 85 В до 265 В).

单相气压等离子切割机。用于切割不锈钢(厚度可达到10mm)和铝材(厚度可达到8mm)。电弧自动启动。21K型切割机,带内置气压机,在缺压缩气连接时仍可继续使用。



Ref. 030954	50/60 HZ		max mm	I _A	X%	Pressure bar	L / mm	Kompressor inside	IP	cm	kg	Protected & compatible POWER GENERATOR (+/- 15%)	Chariot • Trolley Ref 040120			
	A	A														
Plasma CUTTER 21	230-1~	16	5A > 20A	6	4	16A	34%	2,5>4	80	—	23	16,5x43 x26	10,4	4,1 kW	5,9 kVA	•
Plasma CUTTER 21KF	230-1~	16	5A > 20A	6	4	12A	26%	3	40	•	23	21,5x45 x31	17,2	4,1 kW	5,9 kVA	•
Plasma CUTTER 31 FV	230-1~	16	5A > 30A	10	8	22A	32%	2,5>6	115	—	23	18,5x41 x29	12	6 kW	7,5 kVA	•
	110-1~	32	5A > 30A			19A	25%									

Accessoires • Accessories				Consommables • Consumables			
(x1) Ref 040205	(x1) Ref 040199	A (x4)	B (x10)	C (x2)	D (x10)	Ref 71395	

CarDuction 33 (230 V) est un appareil de chauffage mobile par induction d'une puissance de 3300 W. Il est idéal pour décaper les protections anti gravillons des bas de caisse, décoller les tôles soudo-collées, dégripper les écrous et les boulons, déposer les vitres latérales, retirer les baguettes de protection. Il peut être utilisé en carrosserie et également en mécanique.

CarDuction 33 (230V) is a mobile induction heater of 3 300 W. This heater used for removal of anti stone chip sealer, removal of heavy sealers around welded area, heating rusting bolts and nuts, removal of quarter glass, removal of side mouldings. It is designed for professional mechanics and body shop technicians.

CarDuction 33 ist eine tragbare Induktionsstromquelle, die mit einer Leistung von 3,3 KW punktuell Blechteile, Schrauben und Muttern bis zum Glühen erwärmen kann. Ersetzt offene Flammen oder chemische Mittel zum Lösen von festsitzenden z.B. geklebten Teilen.

CarDuction 33 es un aparato de calefacción portátil por inducción, con potencia de 3300W. Es ideal para decapar las protecciones anti-gravilla de largueros bajo puertas, despegar las chapas termo soldadas, desoxidar las tuercas y los pernos, sacar las ventanillas laterales, quitar las varillas de protección. Puede utilizarse en carrocería así como en mecánica.

CarDuction 33 (230V) is een verrijdbare inductie heater van 3300W. De heater wordt gebruikt voor het verwijderen van body coating en kit, het losmaken van verroeste bouten, het verwijderen van plakritten en sierstrippen en emblemen. De inductieheater is ontwikkeld voor professioneel gebruik in werkplaats en schadeherstelbedrijf.

CarDuction 33 è un induttore di calore da 3 300 W. Viene utilizzato per rimuovere anti-rombo, sigillanti spessi intorno alla zone di saldatura, riscaldare bulloni e dadi arrugginiti, rimuovere le guarnizioni dei cristalli e le modanature laterali. È progettato per meccanici professionali e tecnici di carrozzeria.

CarDuction 33 είναι ένας κινητός επαγωγικός θερμαντήρας ισχύος 3300 W. Αυτό ο θερμαντήρας χρησιμοποιείται για την αφαίρεση από αρμόκαλλες, Αστάρια - sealers γύρω από τις περιοχές συγκολλημένων, θερμανση-πύριμα σε Οξείδωμένες βίδες και παξιμάδια, αποκόλληση τζαμιών, αποκόλληση των Πλευρικών διακοσμητικών. Είναι σχεδιασμένο για επαγγελματίες μηχανικούς και φανοποιούς.

CarDuction 33 это передвижной аппарат индукционного нагрева мощностью 3300 Вт. Он идеален для зачистки частей порожков, защищающих от гравия, для разъединения склеено-сваренных листов металла, для удаления ржавчины с гаек и болтов, чтобы их открутить, для снятия боковых стёкол и защитных планок. Его можно использовать как в кузовных цехах, так и в механических мастерских.

CarDuction 33 是一个3300W的便携式电磁感应加热器。它是非常理想的，专门拆卸专门清除车门防撞保护层耐久车底板防护胶、剥离焊接-胶合双工序的金属板、松开螺母和螺栓、拆卸侧窗、拉开防撞条。本机器适用于钣金修复行业，同样也适合一般机械行业。

Complete Kit Included

Décapage • Burning off • Entfernen



Dégrippage • Heating • Lösen



Décollage • Removal • Abkleben

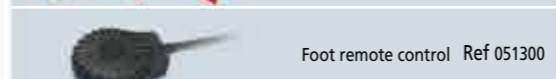

CARDUCTION 33

Ref 051232 =
+ Ref 051249 + Ref 051256 + Ref 051263
+ Ref 051294 + Ref 051300



Accessoires • Accessories

Aide au redressage • Dent pulling help • Ausrichthilfe



Débosselage sans peinture • Paintless dent repair • Ausbeulen ohne Lackieren



Adhesive for logo

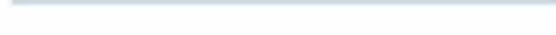

	50/60 Hz	A	W	I ₂ MAX	cm	kg	
CARDUCTION 33	230V	16	3300	60	24 x36 x21	12	•



ANTIPROJECTION/MEULAGE • Anti-projection/grinding
• Anti-proyección/amoladura • Spritzschutz/Schleifen



Ref. 042810 Shade / IR 0
Ref. 042841 Shade / IR 5
Ref. 042827 Shade / IR 0
Ref. 042865 Shade / IR 0

SOUDURE CHALUMEAU
• Torch welding
• Soldadura con soplete
• Autogenschweißen



Ref. 042803 Shade / IR 5
Ref. 042858 Shade / IR 5

MASQUES RESPIRATOIRES JETABLES
• Disposable respirators
• Einweg-Atemschutzmaske
• Máscaras respiratorias desechables



FFP1 (x20) Ref. 043916 EN 149-2001
FFP2D-OV M/L (x5) Ref. 043923 EN 149-2001

TABLIER CUIR MULTI-USAGE
• Leather apron
• Delantal de cuero
• Mehrzweck-Lederschürze



Ref. 045200

GANTS CUIR MULTI-USAGE
• Multi-use leather gloves
• Mehrzweck-Lederhandschuhe
• Guantes de cuero multi-uso



Heavy Duty T10 (MMA - MIG - Plasma) Ref. 045101
Precision T10 (TIG) Ref. 045194

PROTECTION ANTI-ARC 12V
• Anti-arc protection 12V
• Lichtbogenschutz 12V
• Protección anti-arco 12V



Ref. 041318

COUVERTURE ANTI-CHALEUR • Heat cover •
Hitzeschutzdecke-Manta anti-calor • Proteção anti-aquecimento



1200° C / 2200° F 1,75m x 1,50m Ref 050204
550° C / 1000° F 2m x 2m Ref 050495

Mesures • Measurements • Maßnahmen • medidas



GYSMETER, Electronic measurements Ref 052093

MASQUES À CRISTAUX LIQUIDES "LCD" • Autodarkening welding helmets • Automatik-Schweißhelme
• Pantalla electrónica de cristales líquidos • Masker met vloeibare kristallen • Mascara de cristais líquidos

LCD VISION >25A



LCD VISION 11
SHADE 11
MMA • MIG • TIG : 25A > 175A

LCD EXPERT >5A



LCD EXPERT 11
SHADE 11
MMA • MIG • TIG : 5A > 175A

LCD VISION 9/13



LCD VISION 9/13
SHADE 9>13
MMA • MIG : 25A > 400A
TIG : 25A > 300A

LCD EXPERT 9/13



LCD EXPERT 9/13
SHADE 9>13
MMA • MIG : 5A > 400A
TIG : 5A > 300A

LCD ZEUS >5A



SHADE 9>13 MMA • MIG : 5A > 400A
TIG : 5A > 300A
LCD ZEUS BLUE
LCD ZEUS GOLD
LCD ZEUS RED

LCD PREMIUM >5A



SHADE 9>13
MMA • MIG : 5A > 400A
TIG : 5 > 300A
LCD PREMIUM 9/13 SILVER
EXTRA LARGE 97 x 62 mm
4 ARC SENSORS

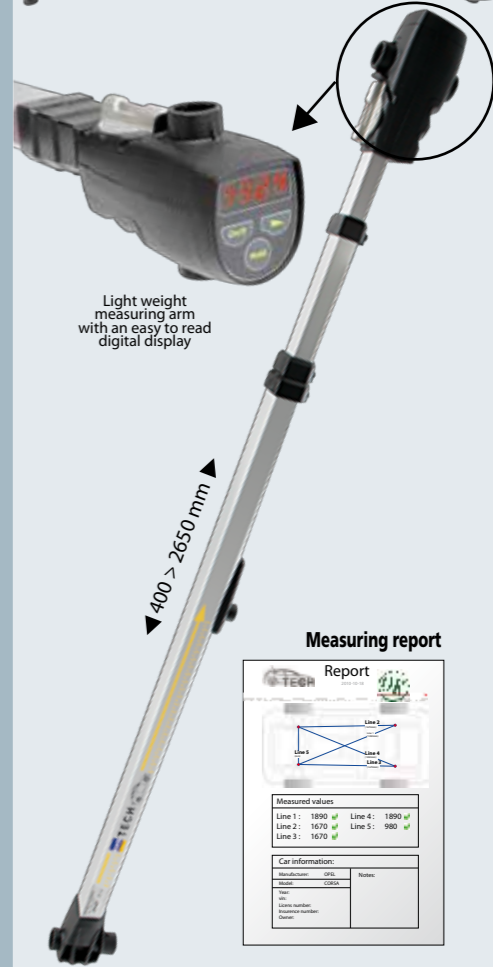

Light weight measuring arm with an easy to read digital display
400 > 2650 mm
Measuring report
Report
Measured values
Line 1 : 1890 µf Line 4 : 1890 µf
Line 2 : 1670 µf Line 5 : 990 µf
Line 3 : 1670 µf
Car information
Manufacturer: GYS
Model: 2204
Year: 2014
License number: 2204
Serial number: 2204



GYSMETER 4W Kit Ref 052123
+ 13 Tools

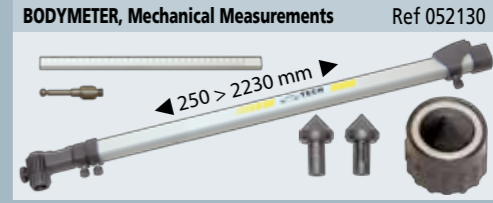

BODYMETER, Mechanical Measurements Ref 052130
250 > 2230 mm

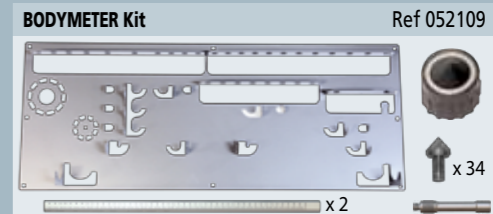

BODYMETER Kit Ref 052109
x 34

Database Online Ref 052116

ÉCRANS • Screens • Scheiben • Pantallas de guardia

	Ref.	ext. mm	int. mm	Box
LCD Vision 11	042728	110x90		x20
	042681		108x51	x2
	042698		108x51	x20
LCD Vision 9/13 (2008) Filter XA 1001F	042728	110x90		x20
	042766		103,5x47	x20
LCD Expert 11 & 9>13	042834	112x91		x20
	042797		96x50	x20
LCD ZEUS Blue, Gold, Red (Filter ADF 7005)	042834	112x91		x20
	042797		96x50	x20
LCD Premium 9/13 Silver	043428	131x114		x20
	043435		99x67	x20

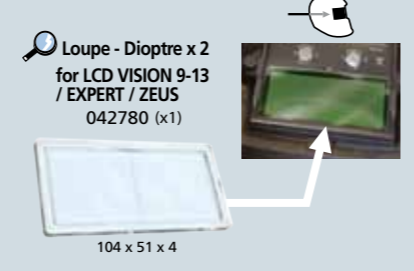

	Teinte Shade	Sensitivity	Delay	Weight
LCD VISION 11	11	0,50	—	430
LCD EXPERT 11	11	0,04	—	430
LCD VISION 9/13	9>13	0,10	•	480
LCD EXPERT 9/13	9>13	0,04	•	430
LCD ZEUS 9/13 (BLUE) Ref. 042230 (GOLD) Ref. 042223 (RED) Ref. 042254	9>13	0,04	•	430
LCD PREMIUM 9/13	9>13	0,04	•	535

Gys Hand Tools • Ausbeulwerkzeug



Hinge Master

Ref. 051102
Redresseur de charnière de porte • Door hinge straightener
• Ausrichter für Türscharnieren • Rectificador de bisagra de puerta



Outils de forme • forming tools • Herramientas • Plaatwerk tassen • Ferramentas • Attrezzatura per riparazione carrozzeria tramite l'uso del martello • 形状工具



Kit débosselage sans peinture • Dent Pulling Kit (without paint) • Dellenausbeulhebel-Set • kit Desabollador (Sin Pintura) • Uitdeuken zonder spuiten set • Kit Tira Mossas (Sem Pintura) • Kit tira-bolli (non richiede la verniciatura) • Набор для правки без зачистки краски • Σετ τραβηκτικό (χωρίς βαφή) • 无需打磨漆腻子机套



Ref. 051959

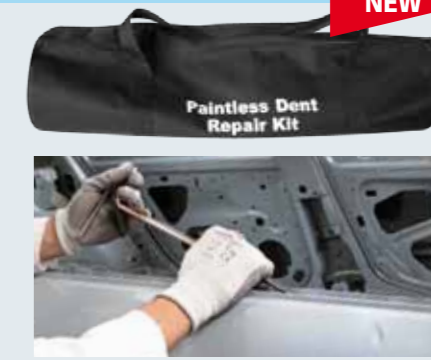

NEW

Pinces • Clamps • Fixier-Klemmen • Pinzas • Grampos



Protections tableau de bord • Dashboard Protector • Armaturen Brett Schutz • Paneles de Protección • Protecções para Painel de Bordo • Dashboard beschermer • Protezione tastiera • Защита для приборной панели • Μάσκα συκόλλησης • 仪表盘保护板



Magnet (x 4)



Ventouses • Suction pads • Saugnapf-Fixierung • Ventosas • zuignappen • Ventose • Вантуз • Βεντούζες • 真空吸盘



Kit marteau inertie • Inertial Hammer Kit • Ausziehhammer Kit • kit Martillos De Inercia • kit Martelo De Inércia • Extra zwaar slaghamerset • Extra zwaar slaghamerset • Kit martello ad inerzia • Обратный молоток в наборе • Σετ σφυριά για την επαναφορά των βαθουλωμάτων • 慣性錘套裝



6 kg Ref. 051928



NEW

Marteau inertie pneumatique • Ausbeulsaughammer • Pneumatische slaghamer



2,5 kg

Ref. 051904



NEW

Kit coussins gonflables • Air Cushion Kit • Luftpolster-Spreizkissen-Satz • Gato neumatico • Kit Almofada Ar • Lucht kussen set • kit cusciniti gonfiabili • Πνευματικές домкраты • Σετ μπλονάκια • 吹气垫子套裝



Ref. 051942



NEW

Outil découpe pare-brise • Windshield Cutting Tool • Windschutzscheiben-Ausglas-Set • Herramienta de corte neumatico • Ferramenta para corte Pára-Brisas • Plakruiten snijset • Taglia-parabrezza • Инструмент для вырезания лобового стекла • Αποκόλλητής παρ-μπριζ • 挡风玻璃切割工具

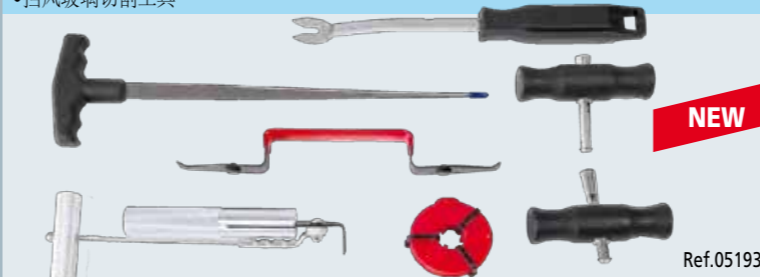

NEW

Ref. 051935

Kit ventouse et sangle • Suction Cup and Strap Kit • Saugnapfheber • Ventosas de tiro • Kit Ventosa e Correia • Zuignap met riempjes • Kit ventose e cinghie • Вакуумный присос и ремень в наборе • Σετ βεντούζα με μίαντα • 真空吸盘和带子套裝



(x2)

NEW

Ref. 051966

Gys Air Jack



Gys Air Jack Car Ref. 051119

Gys Air Jack Van Ref. 051126

2,5T max

2,5T max

34,5 cm max
12 cm min

48 cm max
15 cm min



Kit découpe joint de pare-brise • Windshield Joint-cutting Kit • Scheibentrenn-Werkzeug-Set • Kit de corte neumatico • Kit de corte de juntas de Pára-Brisas • Ruiten snijset • Kit per tagliare la guarnizione del parabrezza • Набор вырезания прокладки лобового стекла • Σετ αποκόλλησης παρ μπιριζ • 挡风玻璃垫条切割工具套裝

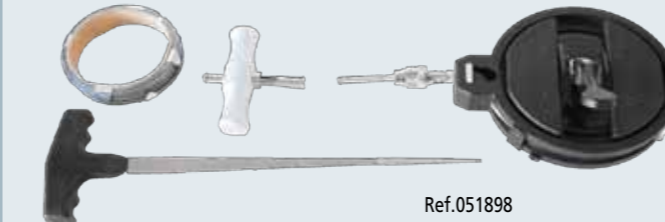

Ref. 051898



Corde à piano carrée (50m) Ref. 051881

Corde à piano torsadée (22m) Ref. 051911

NEW

Coffret décapeuse pneumatique • Pneumatic Scraper Kit • Druckluftentrost-Box inkl. Zubehör • Kit neumatico para arañazos • Kit corte pneumático • Kit scarpello pneumatico • Πνευματική μηχανή για зачистки поверхности в наборе • Σετ τροχός αέρος με συμπυκνωτή • 气动打磨工具套装



NEW



Ref.051775

Speed rpm	Power W	dB	Air consumption L/min	Air pressure bars	l cm	kg
4000	500	86	102	6,2	280	1,2

Perceuse mandrin automatique • Automatic Mandrel Drill • Druckluftbohrmaschine m. Schnellspannfutter • Taladro automatico • Berbequim Pneumático • Mandrino trapano automatico • Дрель с автоматической насадкой • Δράλινο με αυτόματο τσοκ • 自动轧头手摇钻



Ø 13

NEW

Ref.051799

Speed rpm	Power W	dB	Air consumption L/min	Air pressure bar	l cm	kg
800	300	92	170	6,2	18	0,9

Mini-meuleuse • Mini disc sander • Druckluftschleifer • Mini-afiladora • Mini-grosadora



Ø 75

NEW

Ref.051829

Speed rpm	Power W	dB	Air consumption L/min	Air pressure bars	l cm	kg
18000	200	83	171	6,2	12	0,7



Ø 75

Ref.050907

Speed rpm	Power W	dB	Air consumption L/min	Air pressure bars	l cm	kg
18000	150	85	170	6,5	9	0,6

Mini-meuleuse à renvoi d'angle • Mini Angle Grinder • Mini-Druckluftwinkelschleifer geräuschgedämpft • taladro mini angular • Mini Rebarbadora Angular • Mini-mola ad angolo • Угловая шлифовальная машинка • Μίνι γωνιακός τροχός • 小型打磨机



90°

Ø 50

NEW

Ref.051867

Speed rpm	Power W	dB	Air consumption L/min	Air pressure bars	l cm	kg
15000	200	86	85	6,2	18	0,75



90°

NEW

Ref.051836

Speed rpm	Power W	dB	Air consumption L/min	Air pressure bars	l cm	kg
18000	500	81	85	6,2	18	0,7



115°

NEW

Ref.051782

Speed rpm	Power W	dB	Air consumption L/min	Air pressure bars	l cm	kg
18000	500	81	85	6,2	19	0,7

Dépointeuse pour cordon laser • Laser cord metal sheet cutter (nibbler) • Trennwerkzeug für Lasernähte • Mordiscadora para cordón láser • Roedora para corte de chapa com cordão a laser

Indispensable pour Necessary for : Citroën C4 / VW / BMW ...

Ref. 050082



Ref.050099



Dépointeuses • Metal sheet cutter (nibbler) • Druckluft-Schweißpunktböhrer • Mordiscadora • Roedora para corte de chapa

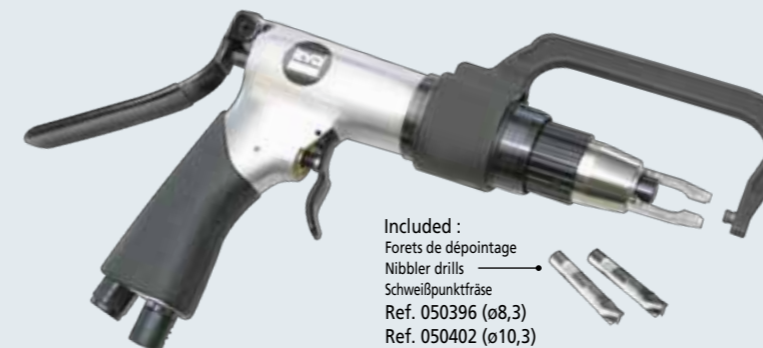

GYSPT DRILL Ref.050464

Included : Forets de dépointage Nibbler drills Schweißpunktfräse Ref. 050396 (ø8,3) Ref. 050402 (ø10,3)

HIGH QUALITY



Speed rpm	Power W	dB	Air consumption L/min	Air pressure bar	l cm	kg
800	400	85	140	6,5	35	2,3

Renov'Polycarbonate • Druckluftpolierer



complete pack Ref.052086



Ø 76

P 500 (x 50) Ref. 052017
P 800 (x 50) Ref. 052024
P 1500 (x 50) Ref. 052031
P 3000 (x 50) Ref. 052048



NEW

Ref. 052079

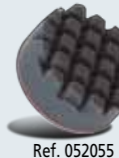

Ref. 052055

Ref. 052062

Sertisseuse pneumatique • Pneumatic Crimper • Druckluftkantenformer • conector neumatico • Agrafadora Pneumática de chapa • Pneumatische tang • Separatore pneumatico • Πνευματικός завальцовщик кромок • Διαμορφωτής αέρος • 气动卷边机



Ref.050419



coups /min	Vibrations m/s ²	dB	Air consumption L/min	Air pressure bar	l cm	kg
2100	2,5	80	400	6	28	2,1

Scie coupe tôle droite et lime • Saw for Straight Cut and File • Druckluftsäge und Feile • Heramienta para cortes rápidos y lijados • Tesoura para corte direito e lima • Attrezzatura per taglio lamiera completa di lime • Прямая пила для стали и напильник • Αερόσαγα με λάμες και λίμες • 铁板锯子



Ref.051805



Speed rpm	Power W	dB	Air consumption L/min	Air pressure bar	l cm	kg
5000	—	85	255	6,2	10	0,8

NEW

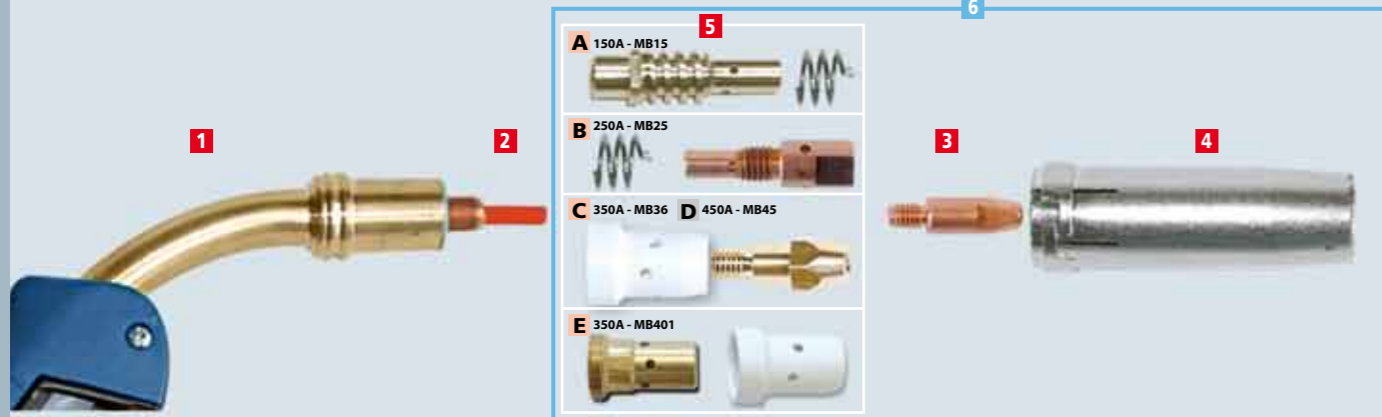

1 TORCHES - Torches - Brenner - Antorcha - Lastoort - Tocha

	I _{max}	L	5	ORIGINAL EQUIPMENT	Ref.
Acier Steel-Stahl Acero-Staal Aço	AIR	150 A	3 m	A M6	Ø 0,8 041424
		250 A	4 m	B M6	Ø 1,0 041455
		350 A	4 m	C M6	Ø 1,2 041714
		450 A	4 m	D M8	Ø 1,2 041394
Inox Stainless	LIQUID	350 A	3 m	C M8	Ø 1,6 041356
Alu	AIR	150 A	3 m	A M6	Ø 0,8 041462
		250 A	3 m	B M6	Ø 0,8 & 1,0 041479
		350 A	3 m	C M6	Ø 1 / Ø 1,6 041721
		450 A	3 m	D M8	Ø 0,8 & 1,6 041400
LIQUID	350 A	3 m	C M8	Ø 1,2 041363	

3 TUBES CONTACTS - Contact tubes - Kontaktrohre - Tubo de contacto - Contactbuis - Pontas de contacto

	Ø 0,6	Ø 0,8	Ø 1,0	Ø 1,2	Ø 1,4	Ø 1,6
Acier	041905	041912	041929			
Alu		041066	041073			
Inox		041790	0419803	0419810	0419827	0419834

2 GAINES - Sheaths - Mantel - Funda - Drahtseelen - Folha

	Ø 0,6 - 0,8	Ø 1 - 1,2	Ø 1,2 - 1,6
Acier Steel	041592	041608	418417
Stahl - Acero	041837	041844	418424
- Staal - Aço			
Teflon :			
Alu - Inox	041578 (0,8)	041585	041585

4 BUSES - Gas nozzle - Düsen - Tubo - Nippel - Bicos

	150 A	250 A	350 A	450 A	350 A
STANDARD	041875	041882	041783	041981	042315
SPECIAL	041813	041561			

PINCE SPÉCIALE MIG-MAG ORIGINAL FIX - Special MIG-MAG plier - Spezial MIG/MAG Zange - Pinza especial MIG MAG

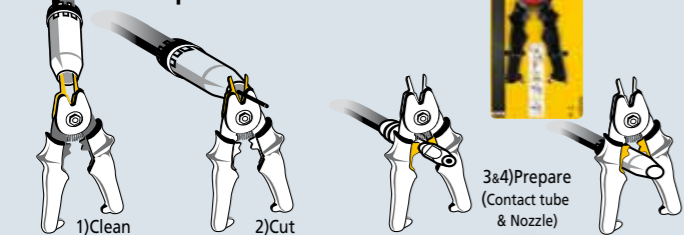

SPRAY PROTECTEUR (SANS SILICONE) - Anti-spatter spray (without silicone) - Antihafspray (Ohne Silicon)



5 PORTE TUBE CONTACT & DIFFUSEUR

	A 150 A	B 250 A	C 350 A	D 450 A	E 350 A
Ref.	042902	042919	042926	042933	042940
Quantity	x5	x5	x5	x5	x5
Accessories	x10 042988	x5 042995	x3 043008	x3 043015	x3 043022

6 COFFRETS - Boxes - Kästen - Cajas - Kistjes - Estojos

	MB15 (150A)	MB25 (250A)
Ref.	041226	041233
OEM	Universal 3P, Monomig 160-1, Monomig 165-4, Trimig 170-4, Trimig 205-4, Trimig 205-4S, Duomig Auto, Duogys Auto	Monomig 250-4, Trimig 255-4, Trimig 255-4S
Accessories	x3, x5 M6 - ø0,6, x5 M6 - ø0,8, Alu x5 M6 - ø0,8	x5, x3, x5 M6 - ø0,8, x5 M6 - ø1,0, Alu x5 M6 - ø1,0

CÂBLE AVEC PINCE DE MASSE - cable with earth clamp - Kabel mit Masseklemme - cable con pinza de masa

	250A	400A	500A
Ref.	043787	043817	043824
Specifications	25 mm ² 10/25 3 m	35 mm ² 35/50 4 m	50 mm ² 35/50 4 m

BOBINES DE FIL - Welding wire reels - Drahtrollen - Bobinas de hilo - Draadbobijn - Bobines de filo

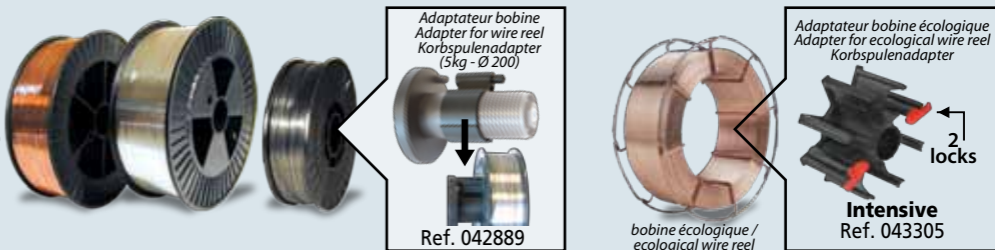

	kg	Q	Ø 0,6	Ø 0,8	Ø 1	Ø 1,2
A Acier (SG2) Steel-Stahl Acero-Staal Aço	0,9	100 mm	—	086593	086609	
	5	200 mm	—	086111	086128	086135
	15	300 mm	—	086166	086227	086234 086241
	18	—	300 mm		086272 (15 kg)	086289 086296
B Galva (G2Ti)	5	200 mm	—	086760	086777	
C Alu (AlMg5)	2	200 mm	—		086555	086562
	7	300 mm	—			086524 086531
D Alu (AlSi5)	0,5	100 mm	—		086685	
Alu (AlSi12)	0,5	100 mm	—		086678	
E Inox-Stainless - Edelstahl	5	200 mm	—		086326	
F Inox-Stainless - Edelstahl	1	100 mm	—		086616	
G CuSi3 HLE - UHTS (Boron Steel)	5	200 mm	—		086647	086654
	1	100 mm	—		086692	
H CuAl8 HLE - UHTS (Boron Steel)	5	200 mm	—		086661	
I Acier / Steel - NO GAZ	4,5	200 mm	—		ø0,9 = 086623	086630
	0,9	100 mm	—		ø0,9 = 086104	

	TYPE	DIN	AWS	EN
A	G2Ti		AWS A 5.18 : ER 70S6	EN 440 : G3 Si 1
B	G3Si1		AWS A 5.18 : ER 70S2	
C	AlMg5	DIN 1732 : AlMg5	AWS A 5.10 : ER 5356	
D	AlSi5		AWS A 5.10 : ER 4043	
E	AlSi12	DIN 1913 : E 51 21 R3	AWS A 5.10 : ER 4047	
F	316LSi		AWS A 5.9 : ER 316L Si	EN 12072 : G19 12 3L
G	308LSi		AWS A 5.9 : ER 308L Si	EN 12072 : G19 9L
H	CuSi3	DIN 1733 : CuSi3	AWS A 5.7 : ER CuSi-A	
I	CuAl8		AWS A 5.7 : ER CuAl-A1	EN 12072 : G19 9L
J	No GAZ		AWS A 5.20 : E71T-G5	EN 758 : T 42 Z W N 1H10

GALETS - Vorschubrollen - Rollen - Rodillos - Wielen - Roletes

	UNIVERSAL 2P	UNIVERSAL 3P	MONOMIG 160-1	MONOMIG 165-4, 250-4, MONOGYS 185-25 TRIMIG 170-4, 205-4, 255-4	TRIMIG 205-4S, 385-4S, T3 GYS DUOGYS AUTO	TRIMIG 255-4S, 385-4S	WF 324 WF 344W >mai 2009	DUOMIG MAGYS 410 WF 324 WF 344W
Acier	0,6/0,8	x1 042339	x1 042339	x1 042339	x1 042087	x2 042353	x2 042353	x2 041738
Steel-Stahl	0,8/1,0				x1 042100	x2 042360	x2 042360	x2 042094
Acero-Staal	1,0/1,2				x1 042179			x2 042117
Aço	1,2/1,6						Ø 1,2 042384	x2 041752
Inox-Stainless							x2 042384	x2 041752
Alu	0,8/1,0				x1 042155	x2 042377	x2 042377	x2 042148
	1,0/1,2				x1 042186			x2 042162
	1,2/1,6						Ø 1,2 042394	x2 041776
NO GAZ	0,9	x1 041172						
	0,9/1,2		x1 042346		x1 042131			x2 042407 x2 042124

GYS Academy, the special training dedicated to importers



CENTRE DE FORMATION

- Groupe de 10 personnes maximum
- Formation pratique sur les dernières soudeuses par point GYS.
- Formation pratique avec les produits MIG GYS
- Formation pratique au redressage et débosselage avec le système GYSLINER.
- Exercices de simulation de démonstration pour améliorer vos techniques de vente.

TRAINING CENTRE

- Group of 10 people maximum
- Practical training with latest GYS Spot welding systems
- Practical training with GYS MIG products
- Practical straightening and dent pulling training with GYSLINER system
- Demonstration simulation exercises to improve your sales techniques and performance

TRAININGZENTRUM

- für Gruppen bis zu 10 Personen
- Praxistraining mit modernster GYS Punktschweißtechnik
- Praxistraining mit GYS MIG/MAG-Geräten
- Praxistraining Ausbeultechnik mit GYSLINER System
- Praxisorientiertes Verkaufs- und Vorführtraining



FRANCE GYS France
 BP 4159
 53941 Saint-Berthevin
 Laval cedex France
 Fax : +33 (0)2 43 68 35 21
 www.gys.fr
 E-mail : contact@gys.fr

GERMANY GYS GmbH
 Krantzstraße 7, Gebäude 15
 D-52070 Aachen - Deutschland
 Tel : +49 (0) 241 / 189-23-710
 Fax : +49 (0) 241 / 189-23-719
 www.gys-schweissen.com
 E-mail : aachen@gys.fr

UNITED KINGDOM GYS Ltd
 Unit 2
 Spartan Close
 CV34 6RS - Warwick - United Kingdom
 Tel : +44 (0) 1926 338 609
 Fax : +44 (0) 1926 429 764
 www.gys-welding.com
 E-mail : uk@gys.fr

CHINA GYS China
 Lot N°15
 6666 bd Songze
 201706 Qingpu Shanghai - China
 Tel : +86 (21) 6221 4461
 Fax : +86 (21) 5226 0067
 www.gysasia.com



Document non contractuel. GYS se réserve le droit de modifier sans préavis les spécifications de ses appareils - Document not contractual.
 GYS reserves the right to modify the specifications of the machines without prior notice.

GYS
 www.gys.fr

Distributed by :

500
 CHAMPION
 OF GROWTH
 2007

INNOVATION
 2009

**European
 Business
 Awards™**
 2009